





## Pro4000 Series Quick Reference Guide

## Important Message About Cartridge Recycling!

### Please Read Before Opening Your Inkjet Cartridge Box

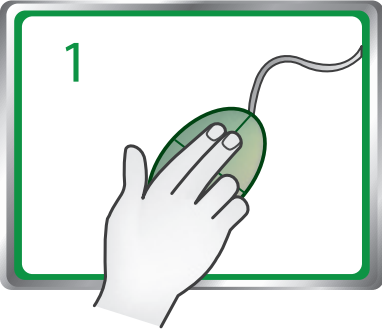
At Lexmark, we take our commitment to the environment seriously, and we encourage our customers to participate in our easy, no-cost method for returning empty Lexmark cartridges to Lexmark for proper recycling. We will insure that cartridges are properly handled with zero waste to landfills.

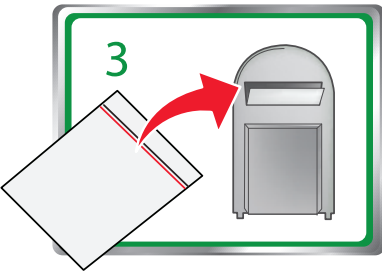
 <p>1</p>	<p>Go to <a href="http://www.lexmark.com/recycle">www.lexmark.com/recycle</a>. Follow instructions to request postage-paid bags. Bags usually arrive within 7–10 days.</p>
 <p>2</p>	<p>Place the empty Lexmark-branded inkjet cartridge or cartridges in the postage-paid return bag, and then seal the bag. If you're sending single-color tanks, we recommend that you send at least two at a time to maximize the environmental benefits.</p>
 <p>3</p>	<p>Mail the bag to Lexmark's recycling partner. The bag is pre-addressed.</p>

Visit [www.lexmark.com/recycle](http://www.lexmark.com/recycle) to learn more about cartridge recycling.

Lexmark-branded cartridges are always made with all new parts, though components may contain recycled material. For warranty returns, call 1-800-395-4039.

This patented printer is licensed for, and designed to work with, only genuine Lexmark inkjet cartridges for the life of the patented printer. You agree to: (1) use only genuine Lexmark inkjet cartridges with this

printer except as otherwise provided below, and (2) pass this license/agreement to any subsequent user of this printer. The patented Lexmark inkjet cartridges and their contents are licensed subject to a restriction that they may be used only once. After this single use, the license to use the print cartridges and their contents terminates, and you agree to return them only to Lexmark for recycling. Replacement inkjet cartridge or cartridges sold without these terms are available through [www.lexmark.com](http://www.lexmark.com) and may be refilled by you, or a third party, as the only cartridge alternative to be used with the licensed printer.

### Important safety information

Connect the power cord to a properly grounded electrical outlet that is near the product and easily accessible.

Do not place or use this product near water or wet locations.

Use only the power supply and power cord provided with this product or the manufacturer's authorized replacements.

 **CAUTION—POTENTIAL INJURY:** To reduce risk of fire, use only the telecommunications (RJ-11) cord provided with this product or a UL Listed 26 AWG or larger replacement when connecting this product to the public switched telephone network.

 **CAUTION—POTENTIAL INJURY:** Do not cut, twist, bind, crush, or place heavy objects on the power cord. Do not subject the power cord to abrasion or stress. Do not pinch the power cord between objects such as furniture and walls. If any of these things happen, a risk of fire or electrical shock results. Inspect the power cord regularly for signs of such problems. Remove the power cord from the electrical outlet before inspecting it.

 **CAUTION—SHOCK HAZARD:** Do not use the fax feature during a lightning storm. Do not set up this product or make any electrical or cabling connections, such as the fax feature, power cord, or telephone, during a lightning storm.

# Contents

- Important safety information.....2**
- About your printer.....5**
  - Finding information about the printer.....5
  - Minimizing your printer's environmental impact.....5
  - Printer models.....5
  - Printer features.....6
  - Setting up the printer.....6
  - Understanding the parts of the printer.....12
  - Using the printer control panel.....14
  - Using memory cards and flash drives.....15
- Ordering and replacing supplies.....17**
  - Ordering ink cartridges.....17
  - Replacing ink cartridges.....17
  - Maintaining ink cartridges.....18
- Using the printer software.....19**
  - Supported operating systems.....19
  - Installing the printer software.....19
  - Using the Windows printer software.....20
  - Using the Macintosh printer software.....20
- Printing.....22**
  - Recommended paper brands.....22
  - Printing a document.....23
  - Printing using advanced color options.....23
  - Printing on both sides of the paper (duplexing) automatically.....23
  - Printing photos from a memory card or flash drive.....24
  - Printing documents from a memory card or flash drive.....24
  - Canceling print jobs.....24
  - Printing from a mobile device.....25

- Copying.....26**
  - Tips for copying.....26
  - Making copies.....26
  - Making a two-sided (duplex) copy automatically.....26
  - Canceling copy jobs.....27
- Scanning.....28**
  - Tips for scanning.....28
  - Scanning to a local computer.....28
  - Scanning to a network folder.....28
  - Scanning to a flash drive or memory card.....29
  - Scanning directly to e-mail using the printer software.....29
  - Scanning to a PDF.....29
  - Canceling scan jobs.....30
- E-mailing.....31**
  - Sending e-mail.....31
  - Canceling an e-mail.....31
- Setting up the printer to fax.....32**
  - Step 1: Connect the printer to the telephone line.....32
  - Step 2: Check the dial tone.....39
  - Step 3: Set your fax name and fax number.....39
  - Step 4: Set the printer to receive faxes automatically or manually.....39
  - Step 5: Set the number of rings.....40
  - Step 6: Create a contact list.....40
- Faxing.....41**
  - Sending faxes.....41
  - Receiving faxes.....41
- Wireless networking.....43**
  - Information you will need during wireless setup.....43
  - Installing the printer on a wireless network.....43

---

What is Wi-Fi Protected Setup?.....	44
Configuring Wi-Fi Protected Setup manually.....	44
<b>Using the Embedded Web Server.....</b>	<b>46</b>
Accessing the Embedded Web Server.....	46
Understanding the home page.....	46
Customizing printer settings.....	46
<b>Using shortcuts.....</b>	<b>48</b>
What are shortcuts?.....	48
Getting started.....	48
<b>Troubleshooting.....</b>	<b>50</b>
<b>Notices.....</b>	<b>60</b>
Edition notice.....	60
<b>Index.....</b>	<b>61</b>

## About your printer

### Finding information about the printer

The *Quick Reference Guide* contains instructions on adding your printer to a wireless network, setting up a fax connection, and accomplishing common printer tasks like printing, copying, scanning, and faxing. It also includes information on troubleshooting printer setup issues as well as solving basic networking and faxing problems.

**Note:** Some functions are available only in select printer models.

For additional information, see the following:

What are you looking for?	Find it here
Initial setup instructions	<ul style="list-style-type: none"> <li>• <i>Quick Setup Sheet</i></li> <li>• Hardware Setup Wizard<sup>1</sup></li> </ul>
Additional setup and instructions for using the printer	<i>User's Guide</i> <sup>2</sup>
Help using the printer software	Software Help installed automatically with the printer software. <sup>2</sup> Click <b>Help</b> from any printer software program or application.
The latest supplemental information, updates, online customer support, and telephone support	Support Web site— <a href="http://support.lexmark.com">http://support.lexmark.com</a>
<sup>1</sup> Available on the <i>Software and Documentation</i> CD. <sup>2</sup> Available on the <i>Software and Documentation</i> CD and on the Lexmark Support Web site at <a href="http://support.lexmark.com">http://support.lexmark.com</a> .	

### Minimizing your printer's environmental impact

We are committed to protecting the environment and are continually improving our printers to reduce their environmental impact. By selecting certain printer settings or tasks, you may be able to reduce your printer's environmental impact even further.

#### Conserving energy

- **Select the lowest Sleep timeout.** The Sleep feature puts the printer in a minimum-power standby mode after the printer has been idle for a set amount of time (the Sleep timeout).
- **Reduce the screen brightness.** Dim the printer display to lower the power consumption of your printer.
- **Share your printer.** Wireless/network printers allow you to share a single printer among multiple computers, thus conserving energy and other resources.

#### Conserving paper

- **Print more than one page image on one side of the paper.** The Pages per Sheet feature allows you to print multiple pages on one sheet. You can print up to 16 page images on one side of a sheet of paper.
- **Print on both sides of the paper.** Two-sided printing (duplexing) lets you print on both sides of the paper manually or automatically (depending on your printer model).
- **Preview print jobs before printing.** Use the preview features found in Toolbars, the Print or Print Preview dialog, or the printer display (depending on your printer model).
- **Use recycled paper.**
- **Reduce the margins of documents to be printed.**
- **Scan and save.** To avoid printing multiple copies, you can scan documents or photos and save them to a computer program, application, or flash drive for presentation (depending on your printer model).

#### Conserving ink

- **Use Quick Print or Draft Mode.** These modes can be used to print documents using less ink than normal and are recommended for printing documents that are mostly text.
- **Use font types and font settings that require less ink.** Most programs or applications let you adjust the darkness of the colors.
- **Use high-yield cartridges.** Inks in high-yield cartridges allow you to print more pages.
- **Preview print jobs before printing.** Use the preview features found in Toolbars, the Print Preview dialog, or the printer display (depending on your printer model).

#### Recycling

- **Return ink cartridges for reuse or recycling through the Lexmark Cartridge Collection Program.** To return an ink cartridge, go to [www.lexmark.com/recycle](http://www.lexmark.com/recycle). Follow the instructions to request a postage-paid bag.
- **Recycle the product packaging.**
- **Recycle your old printer instead of throwing it away.**
- **Recycle paper from discarded print jobs.**
- **Use recycled paper.**

To read the Lexmark Environmental Sustainability Report, see [www.lexmark.com/environment](http://www.lexmark.com/environment).

**Note:** Your printer may not come with some of these programs or some of the functions of these programs, depending on the features of the printer that you purchased.

#### Printer models

The installation software CD that came with your printer works for the following printer models:

- Pro4000
- Pro4000c

## Printer features

Depending on the model, your printer comes with features that will help you manage and accomplish printing and imaging tasks:

- **Wireless or Ethernet networking**—Print and scan from anywhere in your home or office over a secure wireless or Ethernet network, as well as share the printer among multiple computers.
- **Intuitive touch screen**—Use the full-featured color touch screen for fast, easy access to all the printer menus. The large screen also allows you to view and print photos directly from your digital camera or memory device without using a computer.
- **Print**—Print documents and PDFs quickly from a computer or from a USB flash drive. Built-in two-sided printing lets you save money and the environment.
- **Copy**—Copy documents and photos with one-touch, computer-free black or color copying. Enjoy 25% to 400% reduction and enlargement capacity.
- **Scan**—Scan documents and photos fast and easily with the high-resolution scanner. Easily scan to a memory device or to multiple laptops or PCs over a secure wireless network with up to 1200 dpi optical resolution.
- **Fax**—Do standalone black and color faxing at 33.6Kbps modem speed. Other fax features include 99 speed dials, automatic redial, junk fax blocking, and caller ID.
- **Photo printing**—Print high-quality, long-lasting photos directly from digital memory cards, PictBridge-enabled digital cameras, and USB flash drives.
- **SmartSolutions**—Simplify printer tasks that you frequently repeat by creating and customizing your printer solutions. Using the SmartSolutions toolkit on the Web, you can choose the printer tasks that you often perform, apply your custom settings, and download them to your printer as shortcuts that you can easily access anytime. You can also customize your printer with solutions that display your online calendars, online photo albums, RSS feeds, and more.
- **Shortcuts**—Save a set of frequently used printer settings available for a given task and then assign a shortcut name and shortcut number to it. When you want to perform a task with those settings, you can simply select the shortcut number on the printer instead of going through the usual process of adjusting the settings and options.
- **Eco-Mode**—Save energy and paper by activating Eco-Mode. It automatically dims the printer display light, puts the printer into Sleep mode after a specified period of inactivity, and prints on both sides of the paper for print, copy, and fax jobs.

## Setting up the printer

- 1 Unpack the printer.



### Notes:

- Do *not* attach the USB cable until prompted to do so.
  - Place the printer near the computer during setup. If you are setting up on a wireless network, then you may move the printer after setup is complete.
  - Contents may vary by model and region.
- 2 To initiate printer setup using a computer, insert the installation software CD, or download the printer driver.

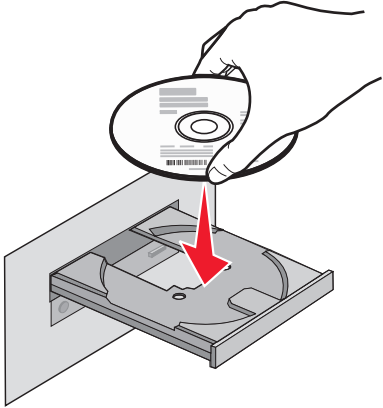
With a CD or DVD drive (Windows/Macintosh)	Without a CD or DVD drive or for Linux
	<p>Download the printer driver from <a href="http://www.lexmark.com">www.lexmark.com</a>.</p>
<p><b>Note:</b> If the installation dialog does not appear after a minute, then see "Installation screen did not appear during installation" on page 50.</p>	

3 Remove tape and packing material from all areas of the printer.

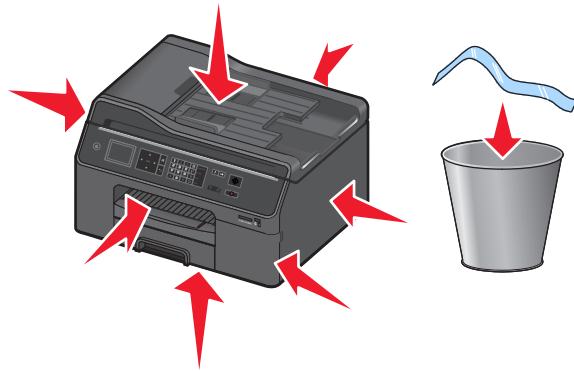

4 If necessary, insert the correct language overlay until it *clicks* into place.

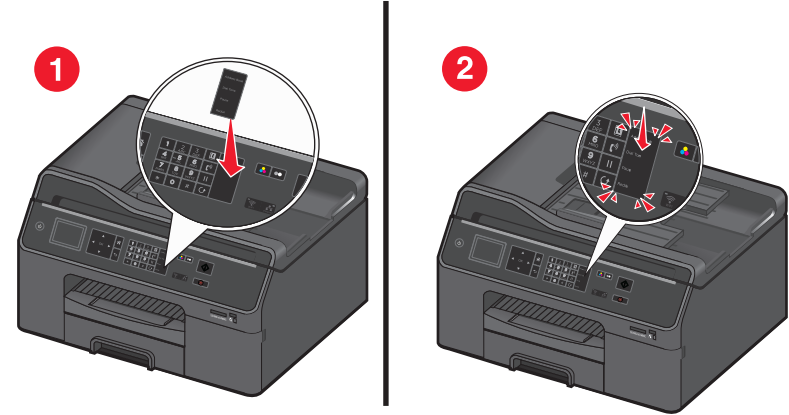

5 Pull the paper tray completely out of the printer.

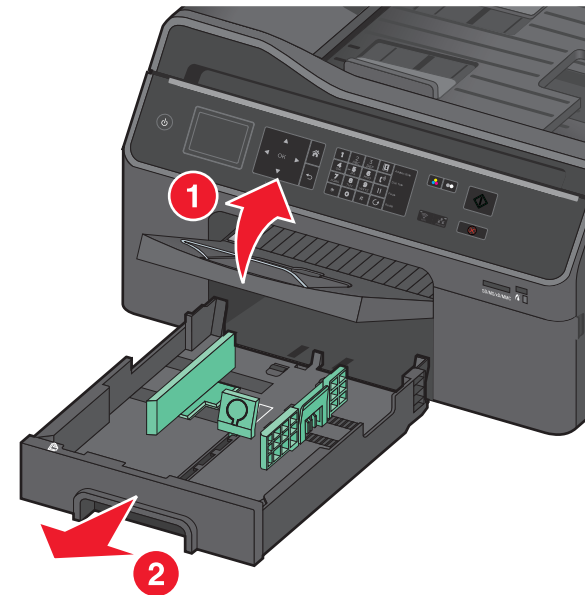

6 Move the paper guides to the sides.

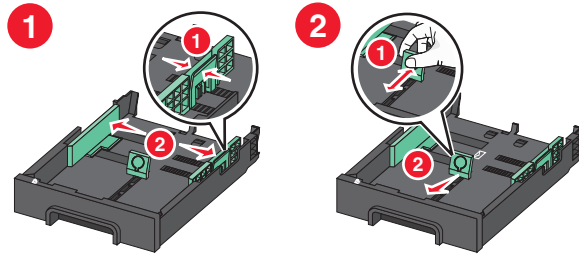

7 For legal-size paper, extend the paper tray.

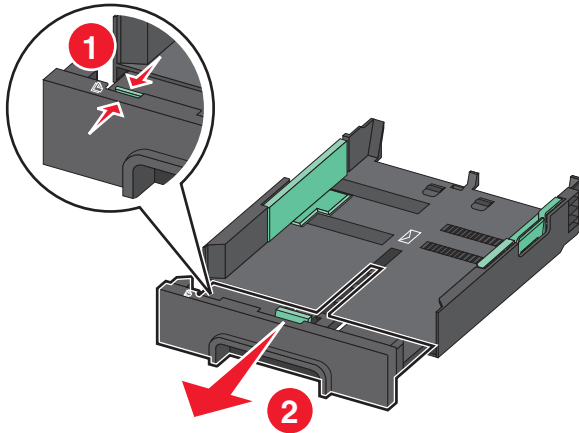

8 Load paper with the printable side facedown.

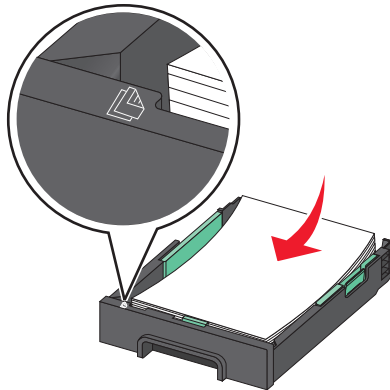

9 Adjust the paper guides to rest against the left, right, and bottom edges of the paper.

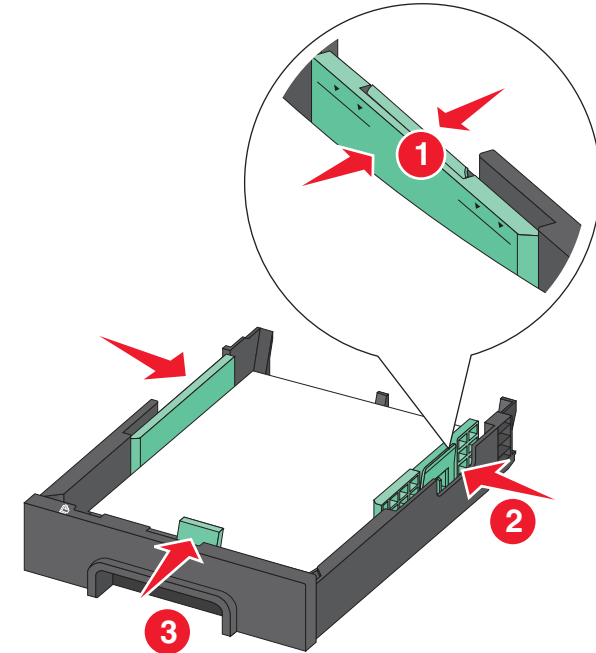

**Note:** Make sure the paper is below the maximum fill line located on the edge of the paper tray. Overloading the tray can cause paper jams.



10 Insert the paper tray.

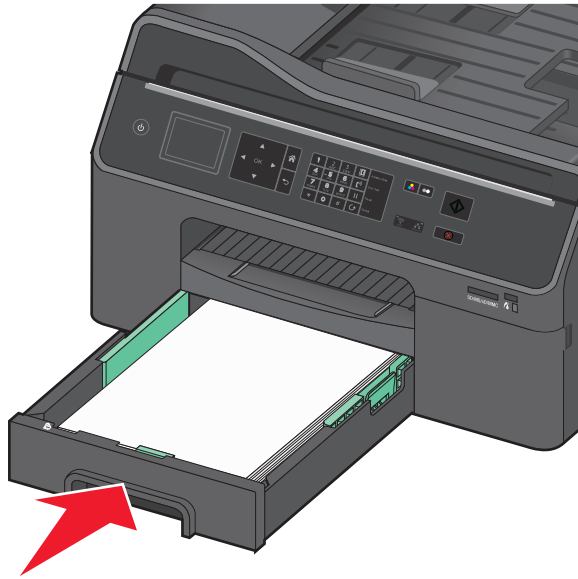

11 Connect the power cord only.

**Note:** Do *not* attach the USB cable yet.

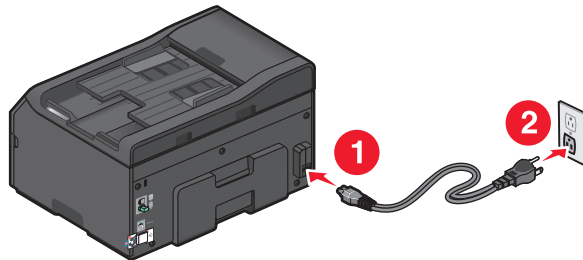

Connect the power cord to a properly grounded electrical outlet that is near the product and easily accessible.

12 Make sure the printer is on.

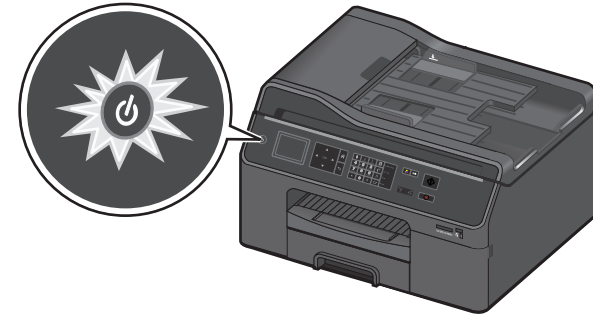

**Note:** It may take a while before the first screen appears on the printer control panel.

13 Using the printer control panel, press the up or down arrow button until the language you want is highlighted on the display, and then press **OK**.

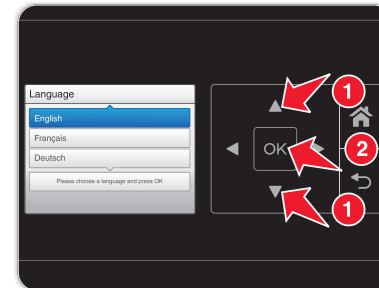

14 Confirm the language, and then press **OK**.

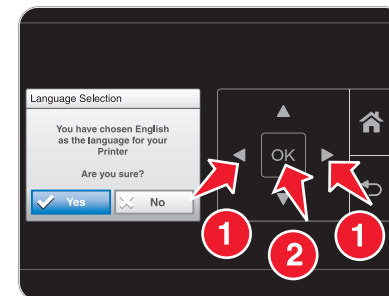

- 15 Set the country or region, and then press **OK**.

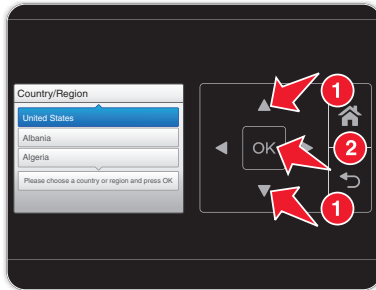

- 16 Using the keypad on the printer control panel, set the date. Press the left or right arrow button to scroll between the month, day, and year. Press **OK**.

**Note:** The date format varies, depending on the selected country or region.

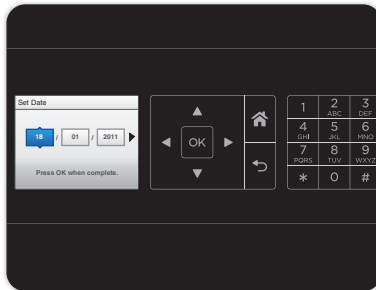

- 17 Set the time, and then press **OK**.

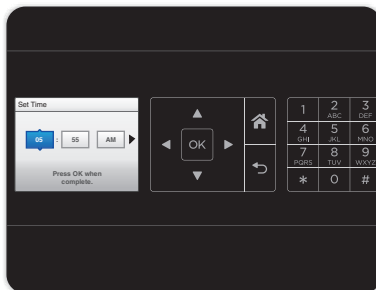

- 18 Set the time zone, and then press **OK**.



**Note:** This step appears only in some countries.

- 19 To configure basic fax functions, press the left or right arrow button until **Now** is highlighted, and then press **OK**. Otherwise, go to step 22.

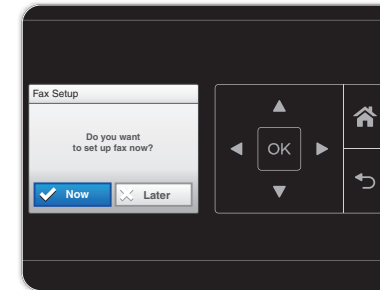

- 20 Enter your fax number for the printer, and then press **OK**. Your fax number identifies you as the sender in all your sent faxes.

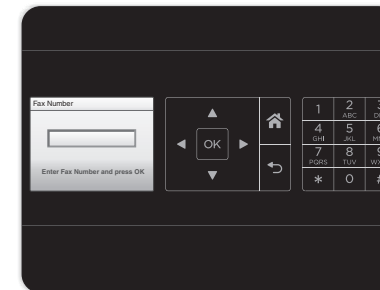

- 21 Type your name or company name, and then press **OK**. Your fax name identifies you as the sender in all your sent faxes.

- To change a character, press the left arrow button.

- To add a space, press the number **0**.

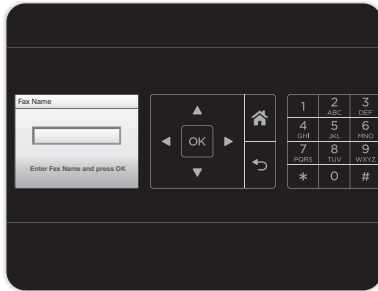

**22** Configure other advanced fax settings later in the software installation.

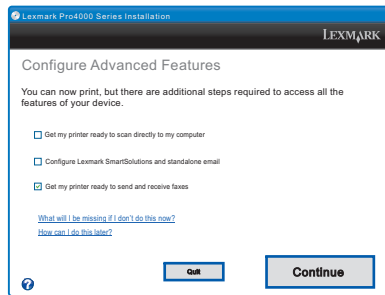

**23** Flip down the ink cartridge access door.

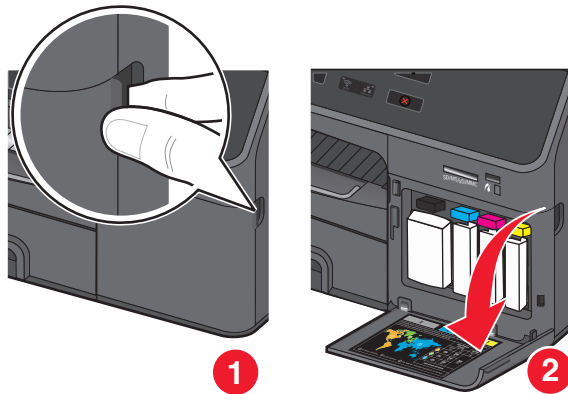

**24** Remove all packing material.

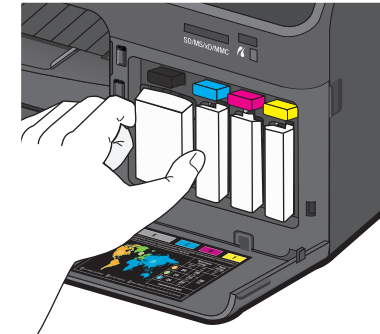

**25** Insert each ink cartridge until it clicks into place.

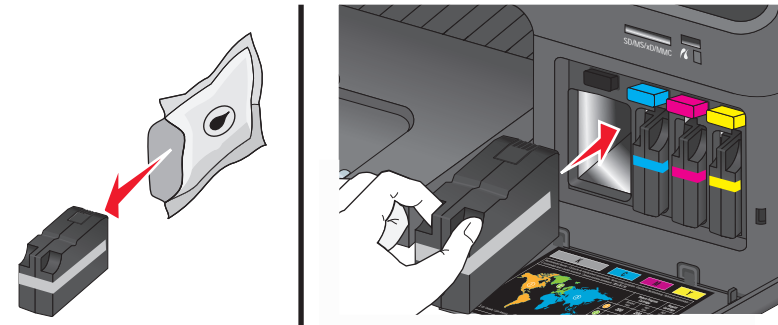

**Note:** Make sure to use the four ink cartridges that came with your new printer.

**26** Close the ink cartridge access door.

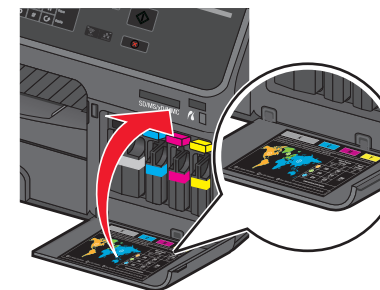

Behind the ink cartridge access door, you will find the customer support label, which contains the ink cartridge information, model number, product Web site, and customer support number.

**Note:** Do not open the ink cartridge access door during the 12-minute printhead preparation.

27 Fully extend the exit bin and flip out the bin extender.

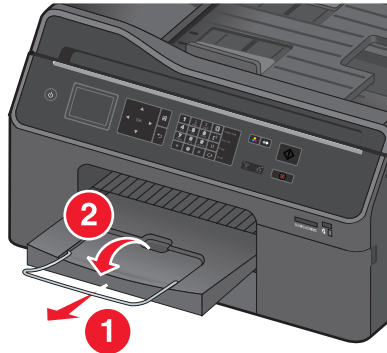

28 From the printer control panel, press **OK** to print an alignment page.



**Notes:**

- The alignment page prints.
- Do not remove the page until printing is finished. The alignment page may take a while to print.
- Streaks on the alignment page are normal and not an indication of a problem.
- The alignment page that prints may differ from the one shown.
- Recycle the alignment page.

## Understanding the parts of the printer

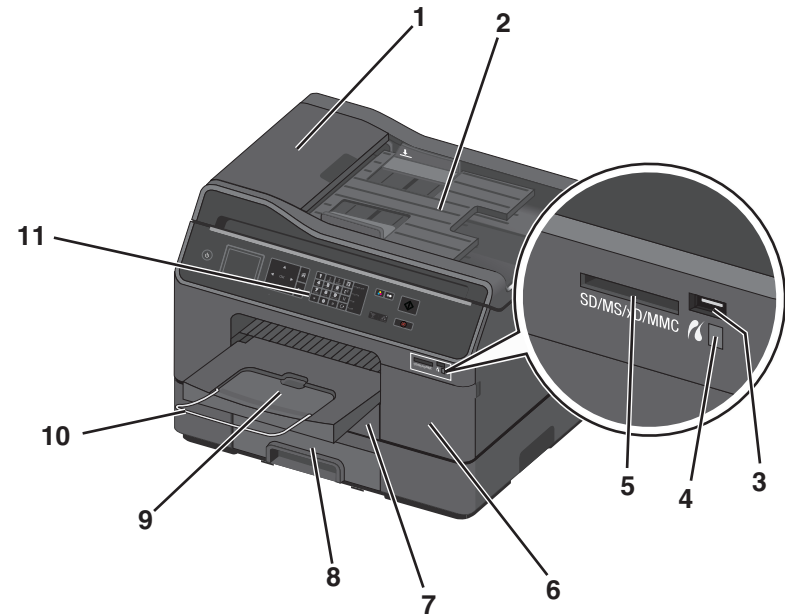

	Use the	To
1	Automatic Document Feeder (ADF)	<ul style="list-style-type: none"> <li>• Scan, copy, or fax multiple-page documents.</li> <li>• Access ADF paper jams.</li> </ul>
2	ADF input tray	Load original documents into the ADF.  <b>Notes:</b> <ul style="list-style-type: none"> <li>• Do not load postcards, photos, small items, or thin media (such as magazine clippings) into the ADF. Place these items on the scanner glass.</li> <li>• After scanning, copying, or faxing, you can lift the right end of the input tray to retrieve the original documents easily.</li> </ul>
3	PictBridge and USB port	Connect a PictBridge-enabled digital camera or a flash drive to the printer.
4	Card reader light	Check the card reader status. The light comes on when a memory card is inserted and blinks when a memory card is being accessed.
5	Memory card slot	Insert a memory card.
6	Ink cartridge access door	Install, remove, or replace ink cartridges.

	Use the	To
7	Paper tray (Tray 1)	Load paper.
8	Second paper tray (Tray 2) <b>Note:</b> This option is available only in select printer models.	Load additional paper. You can load the same type of paper as in Tray 1. You can also load a different type of paper and change the default paper settings so the printer uses paper from Tray 2 for certain types of print jobs.
9	Exit bin	Hold paper as it exits. <b>Note:</b> For the printer to be ready for any print job, make sure to fully extend the exit bin and to flip out the bin extender.
10	Bin extender	Catch the paper as it exits. <b>Note:</b> For the printer to be ready for any print job, make sure to fully extend the exit bin and to flip out the bin extender.
11	Printer control panel	Operate the printer.

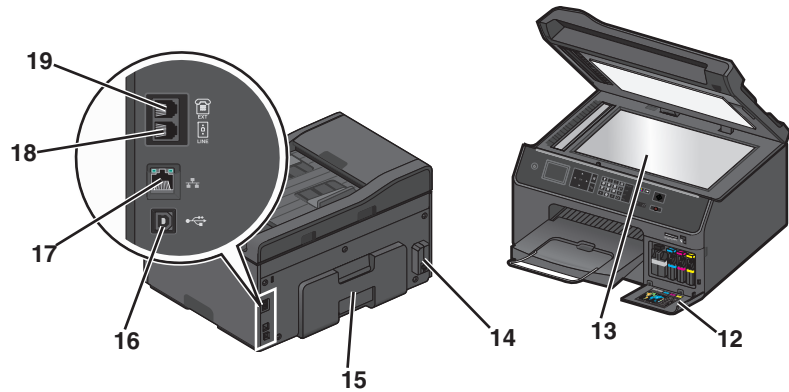





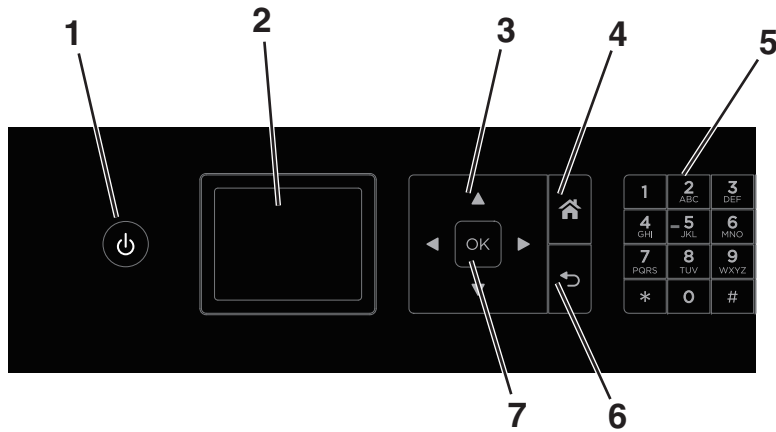

	Use the	To
12	Customer support label	Identify the model number of the printer, the customer support hot line, and the ink cartridge information.
13	Scanner glass	Scan, copy, or fax photos and documents.
14	Power supply with port	Connect the printer to the power cord.
15	Duplex unit	<ul style="list-style-type: none"> <li>Print on both sides of a sheet of paper.</li> <li>Access paper jams.</li> </ul>

	Use the	To
16	USB port	Connect the printer to a computer using a USB cable. <b>Warning—Potential Damage:</b> Do not touch the USB port except when plugging in or removing a USB cable or installation cable. <b>Note:</b> Remove the sticker to access the port.
17	Ethernet port	Connect your printer to a computer, a local network, an external DSL, or a cable modem.
18	LINE port	Connect the printer to an active telephone line through a standard wall jack (RJ-11), DSL filter, or VoIP adapter, or any other adapter that allows you to access the phone line to send and receive faxes.
19	EXT port	Connect additional devices (telephone or answering machine) to the printer and the telephone line. Use this port if you do not have a dedicated fax line for the printer and if this connection method is supported in your country or region. <b>Note:</b> Remove the plug to access the port.



## Using the printer control panel





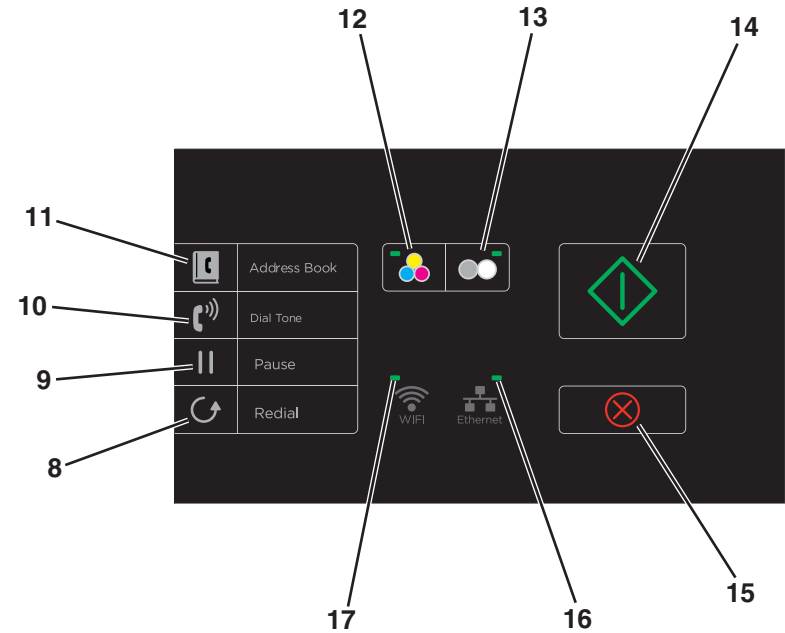



	Use	To
1	 Power	<ul style="list-style-type: none"> <li>Turn the printer on and off.</li> <li>Switch to Sleep mode.</li> </ul> <p><b>Note:</b> When the printer is on, press  to switch to Sleep mode. Press and hold  for three seconds to turn off the printer.</p>
2	Display <b>Note:</b> The display is turned off in Sleep mode.	View: <ul style="list-style-type: none"> <li>Printer status</li> <li>Messages</li> <li>Menus</li> </ul>
3	Arrow buttons	Navigate through menu items that appear on the display.
4	 Home	Return to the home screen.
5	Keypad	In Copy mode or Photo mode: Enter the number of copies or prints you want to make. In Fax mode: <ul style="list-style-type: none"> <li>Enter fax numbers.</li> <li>Operate an automated answering system.</li> <li>Select letters when creating a Speed Dial list.</li> <li>Type numbers to enter or edit the date and time shown on the display.</li> </ul>

	Use	To
6	 Back	<ul style="list-style-type: none"> <li>Return to the previous screen.</li> <li>Exit from one menu level to a higher one.</li> </ul>
7	 Select	<ul style="list-style-type: none"> <li>Select menu options.</li> <li>Save settings.</li> </ul>



	Use	To
8	 Redial	Display the last number dialed. Press the left or right arrow button to view the last five numbers dialed.
9	 Pause	Insert a three-second pause in a fax number to wait for an outside line or get through an automated answering system. Enter a pause only when you have already begun entering the number.
10	 Dial Tone	Dial the telephone number manually using the keypad before sending the fax.

	Use	To
11	Address Book 	Access fax numbers from a saved list of numbers.
12	Color 	Switch to color mode.
13	Black 	Switch to black-and-white mode.
14	Start 	Start a job, depending on which mode is selected.
15	Cancel 	<ul style="list-style-type: none"> <li>Cancel a print, copy, scan, or fax job in progress.</li> <li>Clear current settings or error messages, and return to previous settings.</li> </ul>
16	Ethernet indicator 	Check the Ethernet connection of your printer.
17	Wi-Fi indicator 	Check the wireless connection of your printer. <b>Note:</b> This feature may be available only in select printer models.

## Using memory cards and flash drives

### Supported memory cards and file types

Memory card	File type
<ul style="list-style-type: none"> <li>Secure Digital (SD)</li> <li>Secure Digital High Capacity (SDHC)</li> <li>Micro Secure Digital (with adapter) (Micro SD)</li> <li>Mini Secure Digital (with adapter) (Mini SD)</li> <li>MultiMedia Card (MMC)</li> <li>Reduced Size MultiMedia Card (with adapter) (RS-MMC)</li> <li>MultiMedia Card mobile (with adapter) (MMCmobile)</li> <li>Memory Stick</li> <li>Memory Stick PRO</li> <li>Memory Stick Duo (with adapter)</li> <li>Memory Stick PRO Duo (with adapter)</li> <li>xD-Picture Card</li> <li>xD-Picture Card (Type H)</li> <li>xD-Picture Card (Type M)</li> </ul>	<p>Documents:</p> <ul style="list-style-type: none"> <li>.pdf (Adobe Portable Document Format)</li> </ul> <p>Images:</p> <ul style="list-style-type: none"> <li>.jpg, .jpeg, .jpe (Joint Photographic Experts Group)</li> <li>.tiff, .tif (Tagged Image File Format)</li> </ul>

### Using a memory card or flash drive with the printer

Insert a memory card into the card slot or a flash drive into the USB port.

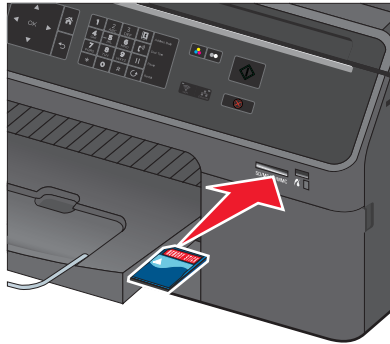
**Inserting a memory card****Notes:**

- Insert the card with the brand name label facing up.
- Make sure any arrows on the card point toward the printer.
- If necessary, connect the memory card to the adapter that came with it.
- Make sure that the memory card inserted is supported by the printer. For more information, see “Supported memory cards and file types” on page 15.
- The card reader light comes on when a memory card is inserted and blinks when a memory card is being accessed.

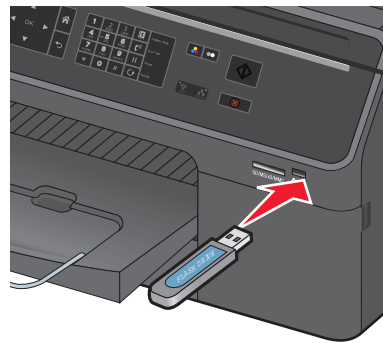
**Inserting a flash drive****Notes:**

- The flash drive uses the same port that is used for a PictBridge camera cable.
- An adapter may be necessary if your flash drive does not fit directly into the port.



**Warning—Potential Damage:** Do not touch any cables, ports, any network adapter, any connector, the memory device, or the printer in the areas shown while actively printing, reading, or writing from the memory device. A loss of data can occur.

Follow the instructions on the printer display or select from available options.

**Notes:**

- If the printer does not recognize the memory device, then remove and reinsert it.
- The printer reads only one memory device at a time.



## Ordering and replacing supplies

### Ordering ink cartridges

Order the cartridges that are designed for use in your region.

- **Region 1:** For the United States, Canada, and Latin America, use 200, 200XL, or 200XLA cartridges.
- **Region 2:** For the European Union (EU), the European Economic Area (EEA), and Switzerland, use 210, 210XL, or 200XLA cartridges.
- **Region 3:** For Africa, the Middle East, Central Eastern Europe (non-EU), the Commonwealth of Independent States (CIS), and the Asia Pacific region, use 220, 220XL, or 200XLA cartridges.

	Return Program Cartridge <sup>1</sup>		Regular Cartridge <sup>2</sup>
	Standard Yield	High Yield	High Yield
①	200	200 XL	200 XLA
②	210	210 XL	
③	220	220 XL	
<a href="http://www.lexmark.com/regions">www.lexmark.com/regions</a>			
① US / Canada / Latin America    ② EU / EEA / Switzerland    ③ Africa / Middle East / Central Eastern Europe (Non EU) / CIS / Asia Pacific			

<sup>1</sup> Licensed for a single use only. After use, return this cartridge to Lexmark for remanufacturing, refilling, or recycling. For more information, visit [www.lexmark.com/regions](http://www.lexmark.com/regions).

<sup>2</sup> Available only on the Lexmark Web site at [www.lexmark.com](http://www.lexmark.com).

#### Notes:

- To get more ink, order high-yield ink cartridges.
- Depending on your country or region, you may get the ink cartridges individually or in packs.
- You can order a mix of standard ink cartridges and high-yield ink cartridges, depending on your needs.
- For page yield information, visit [www.lexmark.com/yields](http://www.lexmark.com/yields).
- The cartridges used for printing documents can also be used for printing photos.
- For best results, use only genuine Lexmark ink cartridges.

### Replacing ink cartridges

Make sure you have a new ink cartridge or cartridges before you begin. You must install new cartridges immediately after removing the old ones, or the ink remaining in the printhead nozzles may dry out.

- 1 Turn on your printer.

- 2 Open the ink cartridge access door.

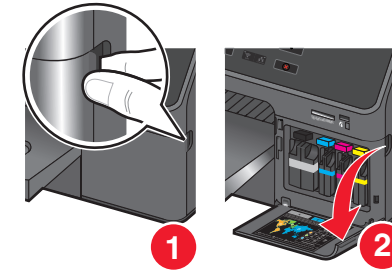

**Warning—Potential Damage:** Do not extend the ink cartridge access door beyond 90 degrees when opening to prevent it from breaking.

- 3 Press the release tab, and then remove the used ink cartridge or cartridges.

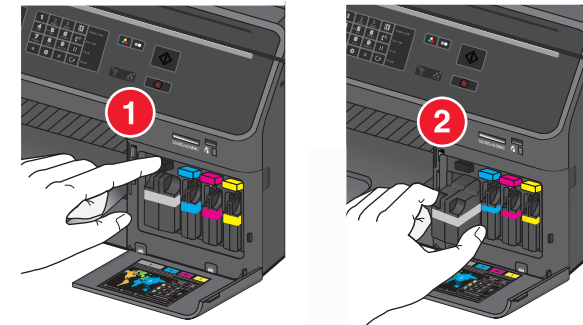

- 4 Insert each ink cartridge until it *clicks* into place.

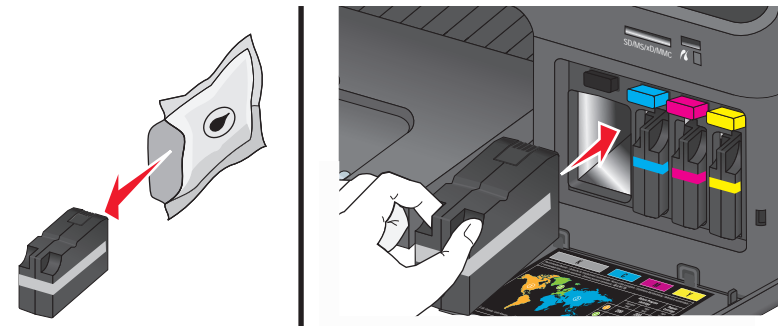

**Note:** Install the new ink cartridges immediately after removing them from the packaging to avoid exposing the ink to air.

5 Close the ink cartridge access door.

**Notes:**

- If **Align Printer** appears on the printer display, then touch **Continue** or press **OK**, depending on your printer model.
- Do not remove the alignment page until printing is finished.

## Maintaining ink cartridges

In addition to the following tasks that you can perform, your printer performs automatic maintenance cycles if it is plugged into a properly grounded, working electrical outlet. It will briefly come out of Sleep mode or will temporarily turn on if it is turned off.

### Aligning the printhead

If the characters or lines on your printed image appear jagged or wavy, then you may need to align the printhead.

- 1 Load plain paper.
- 2 From the printer control panel, navigate to:

🏠 > **Setup** > **OK** > **Maintenance** > **OK** > **Align Printer** > **OK**

An alignment page prints.

**Note:** Do not remove the alignment page until printing is finished.

If you aligned the cartridges to improve print quality, then print your document again. If print quality has not improved, then clean the printhead nozzles.

### Cleaning the printhead nozzles

If you have not been using the printer for a long period, then you may need to clean the printhead nozzles to improve the quality of your prints. Keep your printer plugged to a properly grounded, working electrical outlet to allow it to perform automatic maintenance cycles.

**Notes:**

- Cleaning the printhead nozzles uses ink, so clean them only when necessary.
- Deep cleaning uses more ink, so try the Clean Printhead option first to save ink.
- If the ink levels are too low, then you must replace the ink cartridges before you can clean the printhead nozzles.

- 1 From the printer control panel, navigate to:

🏠 > **Setup** > **OK** > **Maintenance** > **OK**

- 2 Press the up or down arrow button to scroll to **Clean Printhead** or **Deep Clean Printhead**, and then press **OK**.

- 3 Press the up or down arrow button to scroll to a cleaning option, and then press **OK**.

Wait until the printer is ready.

## Moving the printer to another location

When moving the printer and optional trays to another location, follow these precautions:

- Any cart used to move the printer must have a surface able to support the full footprint of the printer. Any cart used to move the options must have a surface able to support the dimensions of the options.
- Make sure the bin extender and the exit bin are in their original positions.
- Keep the printer in an upright position.
- Make sure to remove the ink cartridges from the printer.
- Store the used ink cartridges in a box with the nozzles faceup.

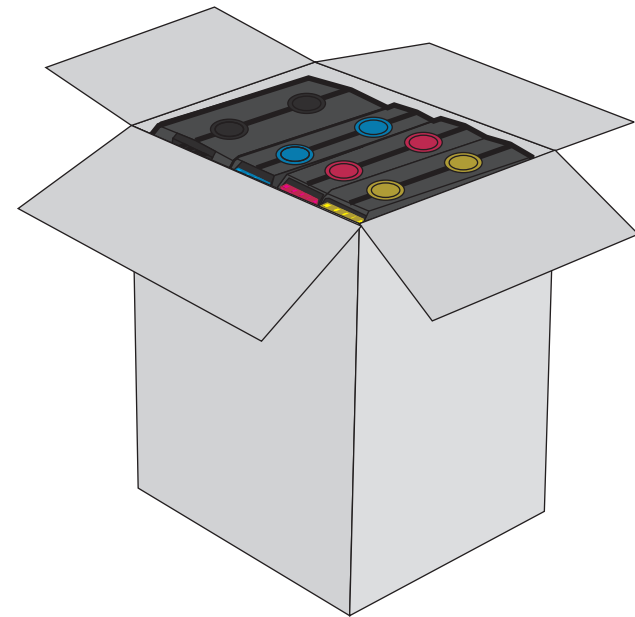

- Avoid severe jarring movements.
- If available, use the original packaging of the printer with the needed padding to keep the printer protected during transport.

## Using the printer software

### Supported operating systems

The printer software requires up to 500MB of free disk space.

- Microsoft Windows 8
- Microsoft Windows Server 2012
- Microsoft Windows 7 (SP1)
- Microsoft Windows 7
- Microsoft Windows Server 2008 (R2)
- Microsoft Windows Server 2008 (SP1)
- Microsoft Windows Server 2003 (SP2)
- Microsoft Windows Server 2003 (SP1)
- Microsoft Windows Vista (SP1)
- Microsoft Windows Vista
- Microsoft Windows XP (SP3)
- Microsoft Windows XP (SP2)
- Macintosh Intel OS X version 10.8.0 or later\*
- Macintosh Intel OS X version 10.7.0 or later
- Macintosh Intel OS X version 10.6.0 or later
- Macintosh Intel OS X version 10.5.0 or later
- Macintosh Intel OS X version 10.4.4 or later\*
- Macintosh PowerPC OS X version 10.5.0 or later
- Macintosh PowerPC OS X version 10.4.0 or later\*
- Debian GNU/Linux 6.0 and 5.0\*
- Fedora 17, 16, 15, and 14\*
- Linpus Linux Desktop 9.6\*
- Linux Mint 12\*
- Linux openSUSE 12.1, 11.4, 11.3, and 11.2\*
- Red Flag Linux Desktop 6.0\*
- Red Hat Enterprise Linux WS 6, WS 5, and WS 4\*
- SUSE Linux Enterprise Desktop 11 and 10\*
- SUSE Linux Enterprise Server 11 and 10\*
- Ubuntu Linux 12.04, 11.10, 11.04, 10.10, 10.04, 9.10, and 9.04\*
- HP-UX 11.31, 11.23, and 11.11\*
- IBM AIX 7.1, 6.1, 5.3, and 5.2\*
- Solaris SPARC 10, 9, and 8\*

- Solaris SPARC x86 10\*

\* The printer driver for this operating system is available only at <http://support.lexmark.com>.

**Note:** Information on additional operating system versions that are compatible with the printer may be available on our Web site.

### Installing the printer software

#### Notes:

- If you installed the printer software on the computer before but need to reinstall the software, then uninstall the current software first.
- Close all open software programs before installing the printer software.

#### 1 Obtain a copy of the software installer package.

- From the *Software and Documentation* CD that came with your printer.
- From our Web site:

Go to <http://support.lexmark.com>, and then navigate to:

**SUPPORT & DOWNLOAD** > select your printer > select your operating system

#### 2 Double-click the software installer package.

Wait for the installation dialog to appear.

If you are using a *Software and Documentation* CD and the installation dialog does not appear, then do the following:

#### In Windows 8

From the Search charm, type **run**, and then navigate to:

Apps list > **Run** > type **D:\setup.exe** > **OK**.

#### In Windows 7 or earlier

- a Click  or click **Start**, and then click **Run**.
- b In the Start Search or Run dialog, type **D:\setup.exe**.
- c Press **Enter**, or click **OK**.

**Note:** D is the letter of your CD or DVD drive.

#### In Macintosh

Click the CD icon on the desktop.

#### 3 Click **Install**, and then follow the instructions on the computer screen.

## Using the Windows printer software

### Software installed during printer installation

When you set up the printer using the installation software CD, all the necessary software was installed. You may have chosen to install some additional programs. The following table provides an overview of various software programs and what they can help you do.

If you did not install these additional programs during initial installation, then reinsert the installation software CD, run the installation software, and then click **Advanced Options > Install Additional Software**.

#### Printer software

Use the	To
Lexmark™ Printer Home (referred to as Printer Home)	<ul style="list-style-type: none"> <li>• Launch applications or programs.</li> <li>• Scan or e-mail a photo or document.</li> <li>• Edit scanned documents.</li> <li>• Scan documents to PDF.</li> <li>• Adjust settings for the printer.</li> <li>• Order supplies.</li> <li>• Maintain ink cartridges.</li> <li>• Register the printer.</li> <li>• Contact technical support.</li> <li>• Access the <i>User's Guide</i>.</li> </ul>
Lexmark Phone Book (referred to as Phone Book)	Manage your fax contacts.
Abby Sprint OCR	Scan a document and produce text that you can edit with a word-processing program.
Lexmark Wireless Setup Utility (referred to as Wireless Setup Utility)	<ul style="list-style-type: none"> <li>• Set up the wireless printer on a wireless network.</li> <li>• Change the wireless settings of the printer.</li> </ul> <p><b>Note:</b> This program is installed automatically with the printer software if the printer has wireless capability.</p>
Lexmark Tools for Office (referred to as Tools for Office)	Access your favorite settings in Microsoft Office 2007.
Printer Setup Utility	Configure the fax and e-mail settings of your printer.
Status Messenger	Learn more about the printing problems encountered.
Status Monitor Center	<ul style="list-style-type: none"> <li>• Check the supplies status of your printer.</li> <li>• Order supplies online.</li> </ul>
Product Update	Receive automatic notifications of updates to your printer software when new updates are available.

Use the	To
Printing Preferences	<p>When you click <b>File &gt; Print &gt; Properties</b> with a document open, a Printing Preferences dialog appears. The dialog lets you select options for the print job, such as the following:</p> <ul style="list-style-type: none"> <li>• Select the number of copies to print.</li> <li>• Print two-sided copies.</li> <li>• Select the paper type.</li> <li>• Add a watermark.</li> <li>• Enhance images.</li> <li>• Save settings.</li> </ul> <p><b>Note:</b> Printing Preferences is installed automatically with the printer software.</p>

**Note:** Your printer may not come with some of these programs or some of the functions of these programs, depending on the features of the printer that you purchased.

## Using the Macintosh printer software

### Launching the Print dialog

Use the Print dialog to adjust the print settings and schedule print jobs.

With a document or photo open, choose **File > Print**.

### Launching an application

- 1 From the Finder, navigate to:  
**Applications >** select your printer folder
- 2 Double-click the application that you want to use.

Use the	To
Printer Settings	<ul style="list-style-type: none"> <li>• Customize settings for fax jobs.</li> <li>• Create and edit the Contacts list.</li> <li>• Configure e-mail connectivity settings.</li> <li>• Configure the language, country, date, and time.</li> </ul>
Shortcuts	Speed up usual tasks with your printer.
Wireless Setup Assistant	<p>Set up the printer on a wireless network.</p> <p><b>Note:</b> This application is automatically installed with the printer software if the printer has wireless capability.</p>
Uninstaller	Remove the printer software from your computer.

**Notes:**

- Your printer may not come with these applications, depending on the features of the printer that you purchased or the installation type (standard or custom) chosen when you installed the printer.
- To take advantage of the full features of your printer, select the custom install option during installation, and then select all packages listed.

**Accessing Web links**

Web links are links to predefined Web pages that are saved in the printer folder.

- 1 From the Finder, navigate to:  
**Applications** > select your printer folder > **Web Links**
- 2 Double-click the Web link that you want to visit.

Use	To
Customer Support	Contact customer support.
Lexmark Software Updates	Download and install the latest printer software.
Lexmark Online	Visit the Lexmark Web site.
Order Supplies Online	Order ink or supplies.
Printer Registration	Register your printer.
Visit Lexmark SmartSolutions	<ul style="list-style-type: none"><li>• Visit the SmartSolutions Web site.</li><li>• Choose your custom solutions.</li></ul>

**Note:** Your printer may not come with these Web links, depending on the features of the printer that you purchased.

# Printing

## Recommended paper brands

### For e-mails, received faxes, internal documents, and similar print jobs

Size	Recommended paper	Weight	Set paper type to
Letter	PrintWorks 30% Recycled Multipurpose Paper #00011	20 lb	Plain
A4	UPM Future Multitech	80 g/m <sup>2</sup>	Plain

### For colorful and high-coverage documents

Size	Recommended paper	Weight	Set paper type to
Letter	Georgia Pacific Everyday Ink Jet and Laser Paper #214305	24 lb	ColorLok Certified Plain
	Hammermill Ultra Premium Laser Print #16600-0 <b>Note:</b> For best results, set Page Dry Time to <b>Extended</b> .	24 lb	Premium Plain
	Georgia Pacific Premium Multipurpose Paper #214306	20 lb	Colorlok Certified Plain
A4	M-Real Data Copy Colour Printing <b>Note:</b> For best results, set Page Dry Time to <b>Extended</b> .	90 g/m <sup>2</sup>	Premium Plain
	SOPORCEL Navigator Universal Multifunctional	80 g/m <sup>2</sup>	Premium Plain

### For résumés, letterhead documents, and similar print jobs

Size	Recommended paper	Weight	Set paper type to
Letter	Wausau Professional Series Royal Linen paper, 30% recycled, #WAU74089	24 lb	Premium Plain

## For photos, brochures, business cards, iron-on transfers, window clings, and other specialty print jobs

Paper and specialty media	One-sided or two-sided printing	Recommended paper	Set paper type to		
Photo	One-sided	Lexmark PerfectFinish™ Photo	Lexmark PerfectFinish Photo		
		Lexmark Photo	Lexmark Photo		
Matte brochure	Two-sided	Inkjet matte brochure papers for light- or moderate-coverage printing: <ul style="list-style-type: none"> <li>• Printworks Matte Photo Paper #00471</li> <li>• Paperworks Inkjet 2-sided Matte Coated 8.5x11 32lb/120g 60pk P/C: PPPJJ32-2</li> </ul> Inkjet matte brochure paper for heavier-coverage printing: <ul style="list-style-type: none"> <li>• Paperworks Inkjet 2-sided Matte Coated 8.5x11 44lb/165g 60pk P/C: PPPJJ44</li> </ul>	Inkjet Matte Brochure		
		Glossy brochure		<ul style="list-style-type: none"> <li>• Red River Zeppelin SemiGloss</li> <li>• Paperworks Inkjet 2-sided Semi-Gloss P/C:PPPJJ48 and Manufacturer #:JANUSSM8511</li> </ul>	Inkjet Glossy Brochure
				Avery specialty	<ul style="list-style-type: none"> <li>• Avery Half-Fold Greeting Cards for Inkjet Printers #3265</li> <li>• Avery Tri-Fold Brochures for Inkjet Printers #8324</li> <li>• Avery Two-Side Printable Clean Edge Business cards for Inkjet Printers #8871</li> </ul>
Iron-on transfer	One-sided	Avery T-shirt Transfers for Inkjet Printers #3271	Iron-On Transfer		
Clear window cling		Micro Format, Inc., Super Color Cling #SP5676	Transparency		
Transparent film		3M Inkjet Transparency Film #CG3480	Transparency		

## Printing a document

### For Windows users

- 1 With a document open, click **File > Print**.
- 2 Click **Properties, Preferences, Options, or Setup**.
- 3 Select the print quality, the number of copies to print, the type of paper to use, and how the pages should print.
- 4 Click **OK** to close any printer software dialogs.
- 5 Click **OK** or **Print**.

### For Macintosh users

- 1 With a document open, choose **File > Page Setup**.
- 2 From the Page Setup dialog, set the printer, paper size, and orientation.
- 3 Click **OK**.
- 4 From the menu bar, choose **File > Print**.
- 5 From the Printer pop-up menu, choose your printer.
- 6 From the print options menu, choose the print quality, the number of copies to print, the type of paper to use, and how the pages should print.
- 7 Click **Print**.

## Printing using advanced color options

Color printing is enabled by default. To optimize print colors for a special print job, use Color Preference and Advanced Color Options.

### For Windows users

- 1 With a document open, click **File > Print**.
- 2 Click **Properties, Preferences, Options, or Setup**.
- 3 Navigate to:  
**Quality** tab > Color Extras area
- 4 Select either **Color Preference** or **Advanced Color Options**.
  - If you select **Color Preference**, then select either **Natural** or **Vivid**.
  - If you select **Advanced Color Options**, then select **Use ICC test Chart Process**.
- 5 From the “Ink to Use” area, select either of the following:
  - **Color + Black** to use four inks including black.
  - **Color Only** to use cyan, magenta, and yellow inks.

- 6 Click **OK** to close any printer software dialogs.
- 7 Click **OK** or **Print**.

### For Macintosh users

- 1 With a document open, choose **File > Print**.
- 2 From the printer pop-up menu, choose your printer.
- 3 From the print options pop-up menu, choose **Quality & Media > Advanced Options**.
- 4 From the “Ink to Use” pop-up menu, choose either of the following:
  - **Color + Black** to use four inks including black.
  - **Color Only** to use cyan, magenta, and yellow inks.
- 5 From the Color Preferences area, choose **Natural** or **Vivid**, or choose **Use ICC Test Chart Process**.
- 6 Click **Print**.

## Printing on both sides of the paper (duplexing) automatically

The automatic duplex unit supports A4-, A5-, letter-, legal-, statement-, and executive-size paper.

### Notes:

- Other paper sizes may be supported.
- Two-sided printing is not supported on envelopes, card stock, or photo paper.
- Do not remove the page until printing is finished.

### For Windows users

- 1 With a document open, click **File > Print**.
- 2 Click **Properties, Preferences, Options, or Setup**.
- 3 Navigate to:  
**Layout** tab > Print on Both Sides (Duplex) area > select **Print on both sides**
- 4 Click **OK** to close any printer software dialogs.
- 5 Click **OK** or **Print**.

To return to single-sided printing, repeat steps 1 and 2, and then navigate to:

**Layout** tab > Print on Both Sides (Duplex) area > select **Print on one side only**

### For Macintosh users

- 1 With a document open, choose **File > Page Setup**.
- 2 From the Page Setup dialog, set the printer, paper size, and orientation.

- 3 Click **OK**.
- 4 From the menu bar, choose **File > Print**.
- 5 From the Printer pop-up menu, choose your printer.
- 6 From the print options pop-up menu, choose **Quality & Media**.
- 7 From the Paper Type pop-up menu, choose **Plain Paper**.
- 8 From the print options pop-up menu, choose **Layout**.
- 9 From the Two-Sided pop-up menu, choose **Long-Edge binding** or **Short-Edge binding**.
  - For Long-Edge binding, pages are bound along the long edge of the page (left edge for portrait, top edge for landscape).

Portrait

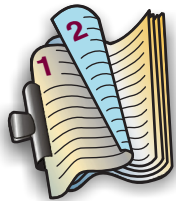

Landscape



- For Short-Edge binding, pages are bound along the short edge of the page (top edge for portrait, left edge for landscape).

Portrait



Landscape

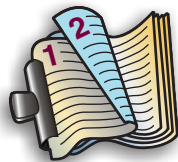

- 10 Click **Print**.

## Printing photos from a memory card or flash drive

- 1 Load photo paper.
- 2 Insert a memory card, flash drive, or digital camera set to mass storage mode.  
If image files and document files are stored in the memory device, then press the left or right arrow button to select **Photos**, and then press **OK**.

**Note:** Only files with supported file types will be shown.

- 3 Use the up or down arrow button to select a photo printing option, and then press **OK**.
  - **Select and Print** allows you to choose a layout, the number of photos per page, paper settings, photo size, photo quality, and to sharpen the quality of graphics.
  - **Print Photos** allows you to print all photos, selected photos by photo range, and print photos using predefined photo size templates.
- 4 To adjust the print settings, press the up or down arrow button to scroll to the option you want to set, and then press the left or right arrow button to scroll to the setting you want. If necessary, press **OK** to make a selection.
- 5 Press .

**Note:** For best results, allow the prints to dry at least 24 hours before stacking, displaying, or storing.

## Printing documents from a memory card or flash drive

To enable the File Print function, the memory card or flash drive must contain document files that are supported by the printer. For more information, see “Supported memory cards and file types” on page 15.

- 1 Insert a memory card or flash drive.  
The Memory Device screen appears on the display.
- 2 Touch **Print Documents**.
- 3 Select the document that you want to print, and then press .

## Canceling print jobs

To cancel a print job from the printer control panel, press , and then press **OK**. Printing stops and the printer returns to the home screen.

To cancel a print job from the computer, do the following:

### For Windows users

- 1 Open the printers folder.

#### In Windows 8

From the Search charm, type **run**, and then navigate to:

Apps list > **Run** > type **control printers** > **OK**

#### In Windows 7 or earlier

- a Click , or click **Start** and then click **Run**.
- b In the Start Search or Run dialog, type **control printers**.



- c Press **Enter**, or click **OK**.
- 2 Double-click the printer icon.
- 3 Cancel the print job:
  - If you want to cancel a particular print job, then right-click the document name, and then select **Cancel**.
  - If you want to cancel all print jobs in the queue, then click **Printer > Cancel All Documents**.

### For Macintosh users

- 1 Click the printer icon on the Dock.  
The print queue dialog appears.
- 2 Select the print job you want to cancel, and then delete it.

## Printing from a mobile device

### What is LexPrint?

LexPrint is a free application that lets you print easily from your iPad, iPhone, or iPod touch using any Lexmark printer connected to the same wireless network. It lets you print Web pages, photos from the photo album, or photos you recently captured using the camera of your mobile device, depending on its features. You can also customize print settings from your mobile device.

Depending on your Lexmark printer model, you may need to download the LexPrint Listener application from our Web site at [www.lexmark.com/lexprint](http://www.lexmark.com/lexprint).

### Supported printers

LexPrint enables your mobile device to communicate with Lexmark printers found on the same network.

- For select printer models that support Direct Image and Zeroconf or Bonjour, you can print directly from your mobile device to the printer without using LexPrint Listener. To check if your printer model supports these features, visit [www.lexmark.com/lexprint](http://www.lexmark.com/lexprint).
- For other Lexmark printers, your mobile device can send print jobs to your printer as long as the printer software and **LexPrint Listener** are installed on the computer where the printer is connected.

**Note:** The application referred to as *Rendezvous* in Mac OS X version 10.2 is now called *Bonjour* by Apple Inc.



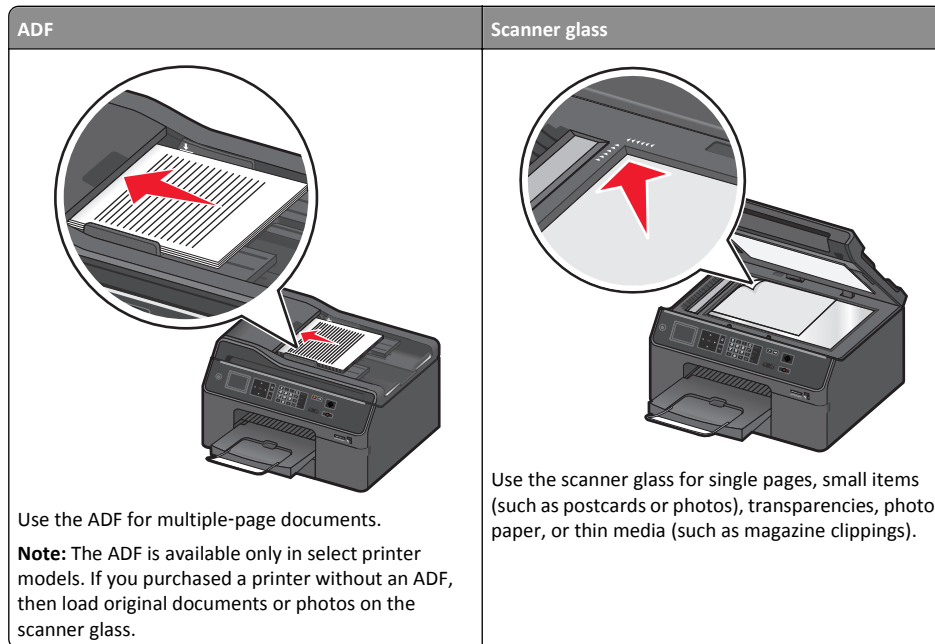

## Copying



### Tips for copying

- Make sure the exit bin is fully extended and the bin extender is flipped out.
- Use the ADF when scanning two-sided pages if your printer supports duplex scanning and the ADF supports the original document size.
- Use the scanner glass when scanning two-sided pages if your printer does not support duplex scanning or the ADF does not support the original document size.
- When using the ADF, adjust the paper guides on the ADF to the width of the original document.
- To easily retrieve a document after copying or scanning, lift the ADF input tray.
- When using the scanner glass, close the scanner cover, if possible, to avoid dark edges on the scanned image.
- Do *not* load postcards, photos, small items, transparencies, photo paper, or thin media (such as magazine clippings) into the ADF. Place these items on the scanner glass.
- When the document to be copied is in place with the settings you want, press  to start copying.

### Making copies

- 1 Load paper.
- 2 Load an original document faceup into the ADF or facedown on the scanner glass.
- 3 From the printer control panel, navigate to:
  - Home > Copy >  > Copies
- 4 Press the left or right arrow button to select the number of copies.
- 5 From the Copy menu screen, press the up or down arrow button to scroll to the option you want to set, and then press the left or right arrow button to scroll to the setting you want. If necessary, press  to make a selection.
- 6 Select the copy mode:
  - Press  to switch to color mode.
  - Press  to switch to black-and-white mode.

When you select color or black-only printing, the light that corresponds to your choice comes on.
- 7 Press .

**Note:** The selected copy settings are reset to the factory default after two minutes of printer inactivity.

### Making a two-sided (duplex) copy automatically

The automatic duplex unit supports A4-, A5-, letter-, legal-, and executive-size paper. If you need to make two-sided copies using other paper sizes, then see the instructions for making a two-sided copy manually.



**Note:** You cannot make two-sided copies on envelopes, card stock, or photo paper.

- 1 Load paper.
- 2 Load the original document faceup into the ADF or facedown on the scanner glass.
 

**Notes:**

  - Make sure you load only one page at a time.
  - If the original document is one-sided, then you can use either the ADF or the scanner glass.
  - If the original document is two-sided, then you can use only the scanner glass.
- 3 From the printer control panel, navigate to:
  - Home > Copy >  > 2-Sided Copies
- 4 Press the left or right arrow button to select a two-sided copying option:
  - If you are copying a one-sided document, then press the arrow buttons to scroll to **1-sided to 2-sided**.
  - If you are copying a two-sided document, then press the arrow buttons to scroll to **2-sided to 1-sided** or **2-sided to 2-sided**.

**Notes:**

- If you want to specify the page orientation and layout of the original document and the copy, then press the arrow buttons to scroll to **Advanced**. Press  every time you make a selection, and then press  until you reach the Copy menu.
- For long-edge binding, pages are bound along the long edge of the page (left edge for portrait orientation and top edge for landscape orientation).
- For short-edge binding, pages are bound along the short edge of the page (top edge for portrait orientation and left edge for landscape orientation).

5 Press , and then follow the instructions on the printer display.

## Canceling copy jobs

To cancel a copy job, press , and then press .

Scanning stops and the printer returns to the previous menu.

## Scanning

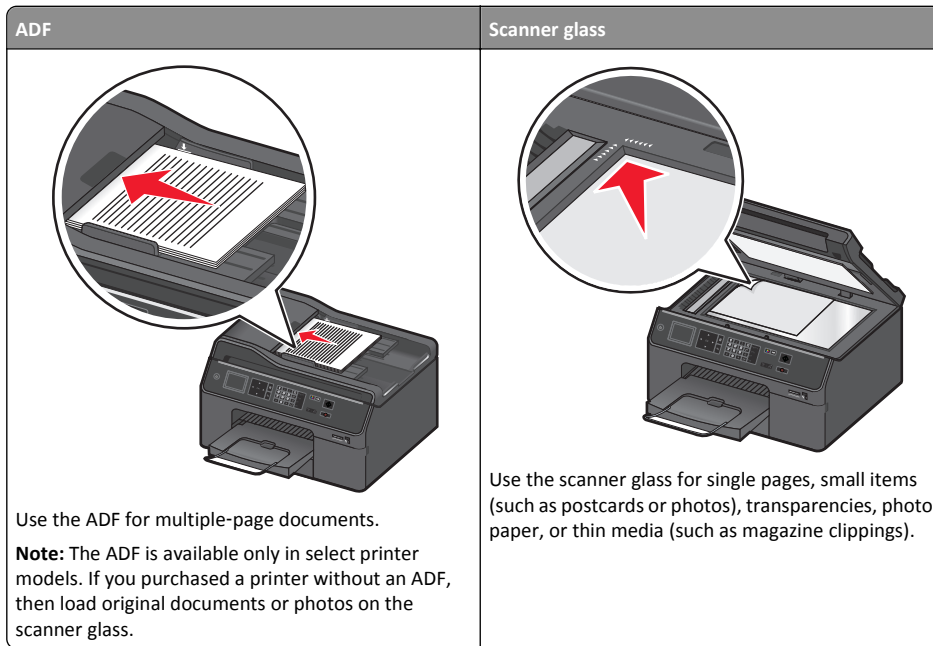



### Tips for scanning

- Use the ADF when scanning two-sided pages if your printer supports duplex scanning and the ADF supports the original document size.
- Use the scanner glass when scanning two-sided pages if your printer does not support duplex scanning or the ADF does not support the original document size.
- When using the ADF, adjust the paper guides on the ADF to the width of the original document.
- To easily retrieve a document after copying or scanning, lift the ADF input tray.
- When using the scanner glass, close the scanner cover, if possible, to avoid dark edges on the scanned image.
- Do *not* load postcards, photos, small items, transparencies, photo paper, or thin media (such as magazine clippings) into the ADF. Place these items on the scanner glass.
- When the document to be scanned is in place with the settings you want, press  to start scanning.

### Scanning to a local computer

- 1 Load the original document faceup into the ADF or facedown on the scanner glass.
- 2 From the printer control panel, navigate to:

 > Scan >  > Computer > USB-Connected Computer > 

The USB-connected computer will receive the scan by default.

**Note:** Make sure the scan software is installed on the destination computer.

- 3 Press the up or down arrow button to scroll to the scan option you want to set, and then press the left or right arrow button to scroll to the setting you want.

Set the color, quality, original image size, and other scan options. If necessary, press  each time you make a selection.







- 4 Press .

### Scanning to a network folder

#### Notes:

- This feature may not appear in the Embedded Web Server, depending on your printer model.
- Make sure you have created a folder shortcut before you begin. For more information, see “Adding a network folder shortcut” on page 28.

- 1 Load the original document faceup into the ADF or facedown on the scanner glass.
- 2 From the printer control panel, navigate to:
 

 > Scan >  > Network Folder > 
- 3 Press the left or right arrow button to scroll to the name of the network shared folder you want, and then press .
- 4 Press the up or down arrow button to scroll to the scan option you want to set, and then press the left or right arrow button to scroll to the setting you want.
- 5 Set the color, quality, original image size, and other scan options. If necessary, press  each time you make a selection.
- 6 Press .

**Note:** For Macintosh users, you may need to enable scanning to your computer through Image Capture to scan documents using a network printer and save the scan output.

### Adding a network folder shortcut

- 1 On your computer, create a shared folder with read/write access.
- 2 On a Web browser, type your printer IP address, and then press **Enter**.

- 3 Navigate to either of the following:
  - **Settings > Scan-to-Network Folder Setup**
  - **Settings > Manage Shortcuts > Add New Shortcut > Scan to Network**
- 4 Enter the necessary information, and then click **Add**.

**Note:** To avoid unsaved changes to your settings, make sure the network folder shortcut name is different from that of your folder name.

## Scanning to a flash drive or memory card

### Notes:

- Some features are available only in select printer models.
  - Make sure your flash drive or memory card is not write-protected.
- 1 Load the original document faceup into the ADF or facedown on the scanner glass.

- 2 From the printer control panel navigate to:

 > **Scan** >  > **Memory Device**

- 3 Insert the flash drive or memory card, and then press .

**Note:** The printer reads only one memory device at a time.

- 4 Press the up or down arrow button to scroll to the scan option you want to set, and then press the left or right arrow button to scroll to the setting you want.

Set the color, quality, original image size, and other scan options. If necessary, press  each time you make a selection.

- 5 Press .

Follow the instructions on the printer display.

## Scanning directly to e-mail using the printer software

Make sure you have set up your e-mail settings before proceeding. For more information, see the section on e-mailing in the *User's Guide*.

### For Windows users

- 1 Load an original document faceup into the ADF or facedown on the scanner glass.
- 2 From the computer, do the following:

#### In Windows 8

From the Search charm, type **Printer Home**, and then navigate to:

**Printer Home** > select your printer > **Scan**

### In Windows 7 or earlier

- a Click  or **Start**.
- b Click **All Programs** or **Programs**, and then select the printer program folder from the list.
- c Navigate to:
  - Printer Home** > select your printer > **Scan**

- 3 Select **Email photo**, **Email document**, or **Email PDF**.

**Note:** You can select **Email document** only when an OCR application is stored on your computer.

Scanning starts and the scan progress dialog appears. When the scan is finished, a new e-mail message is created with the scanned document automatically attached.

- 4 Compose your e-mail message.

**Note:** If your e-mail program does not open automatically, then you can scan the document to the computer, and then send it through e-mail as an attachment.

### For Macintosh users

- 1 Load an original document faceup into the ADF or facedown on the scanner glass.
- 2 From the Finder, select **Applications**, and then launch the application you want to use.

**Note:** Use any application that supports both your printer and an e-mailing option, such as Image Capture.

- 3 From the list of devices, select your printer.

**Note:** For information on finding the list of devices, check the documentation that came with the application, or search for **Scanning an image** in the Search field of the Help menu.

- 4 Adjust the scan settings as needed.

If applicable, click  on the preview dialog for more information.

- 5 Set the e-mail application as the scan destination, and then start the scan job.
- 6 Compose your e-mail message.

## Scanning to a PDF

### For Windows users

- 1 Load an original document faceup into the ADF or facedown on the scanner glass.
- 2 From the computer, do the following:

#### In Windows 8

From the Search charm, type **Printer Home**, and then navigate to:

**Printer Home** > select your printer > **Scan > PDF**

### In Windows 7 or earlier



- a Click  or **Start**.
  - b Click **All Programs** or **Programs**, and then select the printer program folder from the list.
  - c Navigate to:  
**Printer Home** > select your printer > **Scan** > **PDF**
- Scanning starts and the scan progress dialog appears.
- 3 Save the document as a PDF.

### For Macintosh users

- 1 Load an original document faceup into the ADF or facedown on the scanner glass.
- 2 From the Finder, select **Applications**, and then launch the application you want to use.  
**Note:** Use any application that supports your printer.
- 3 From the list of devices, select your printer.  
**Note:** For information on finding the list of devices, check the documentation that came with the application or search for **Scanning an image** in the Search field of the Help menu.
- 4 Adjust the scan settings as needed.  
  
If applicable, click  on the preview dialog for more information.
- 5 Set the application that supports the PDF format as the scan destination, and then start the scan job.
- 6 Save the document as a PDF.

## Canceling scan jobs

Do one or more of the following:

- From the printer control panel, press , and then press .
- Scanning stops and the printer returns to the previous menu.
- If you are sending the scan job using the printer software, then cancel the scan job from the software dialog.

## E-mailing

You can use your printer to send e-mail to one or more recipients without using a computer provided you have set up the scan to e-mail task through shortcuts. For more information, see the section on shortcuts in the *Quick Reference Guide*.

Before you can send e-mail using the printer control panel, you must first configure the network connection and e-mail settings of your printer.

## Sending e-mail

### Tips for e-mailing

- Make sure to enter your e-mail account information and set up the SMTP server before sending an e-mail.
- Make sure the printer is connected to an Ethernet or wireless network before sending an e-mail. If necessary, make sure the network is connected to the Internet for the printer to communicate with the SMTP server. If the printer cannot connect to the Internet, then contact your system support person. The printer supports only one active network connection (Ethernet or wireless) at a time.
- Add contacts to your address book. When sending an e-mail, you can just select contacts from your address book instead of typing their e-mail addresses repeatedly.
- Use the ADF when scanning two-sided pages if your printer supports duplex scanning and the ADF supports the original document size.
- Use the scanner glass when scanning two-sided pages if your printer does not support duplex scanning or the ADF does not support the original document size.
- When using the ADF, adjust the paper guides on the ADF to the width of the original document.
- To easily retrieve a document after copying or scanning, lift the ADF input tray.
- When using the scanner glass, close the scanner cover, if possible, to avoid dark edges on the scanned image.
- Do *not* load postcards, photos, small items, transparencies, photo paper, or thin media (such as magazine clippings) into the ADF. Place these items on the scanner glass.
- When the document to be e-mailed is in place with the settings you want, press  to start scanning.

## Setting up the e-mail function

### For Windows users

- 1 Run the E-mail Setup Wizard.

#### In Windows 8

From the Search charm, type **Printer Home**, and then navigate to:

Apps list > **Printer Home** > select your printer > **Settings** > **Set up the printer to e-mail**

#### In Windows 7 or earlier

- a Click  or **Start**.
- b Click **All Programs** or **Programs**, and then select the printer program folder from the list.
- c Navigate to:  
**Printer Home** > select your printer > **Settings** > **Set up the printer to e-mail**

The E-mail Setup Wizard opens.



- 2 Follow the instructions on the computer screen.

#### For Macintosh users

- 1 From the Finder, navigate to:  
**Applications** > select your printer folder > **Printer Settings** > **Email**
- 2 Follow the instructions on the computer screen, and then click **Save Settings**.

## Canceling an e-mail

Do one or more of the following:

- From the printer control panel, press , and then press .
- If you are sending the e-mail using the printer software, then cancel the e-mail from the software dialog.

## Setting up the printer to fax

**CAUTION—SHOCK HAZARD:** Do not use the fax feature during a lightning storm. Do not set up this product or make any electrical or cabling connections, such as the power supply cord or telephone, during a lightning storm.

**CAUTION—POTENTIAL INJURY:** To reduce risk of fire, use only the telecommunications (RJ-11) cord provided with this product or a UL Listed 26 AWG or larger replacement when connecting this product to the public switched telephone network.

### Step 1: Connect the printer to the telephone line

Check the scenarios below and follow the setup that is applicable to your telephone service.

#### Scenario 1: Standard telephone line

##### Setup 1: Printer is connected to a dedicated fax line

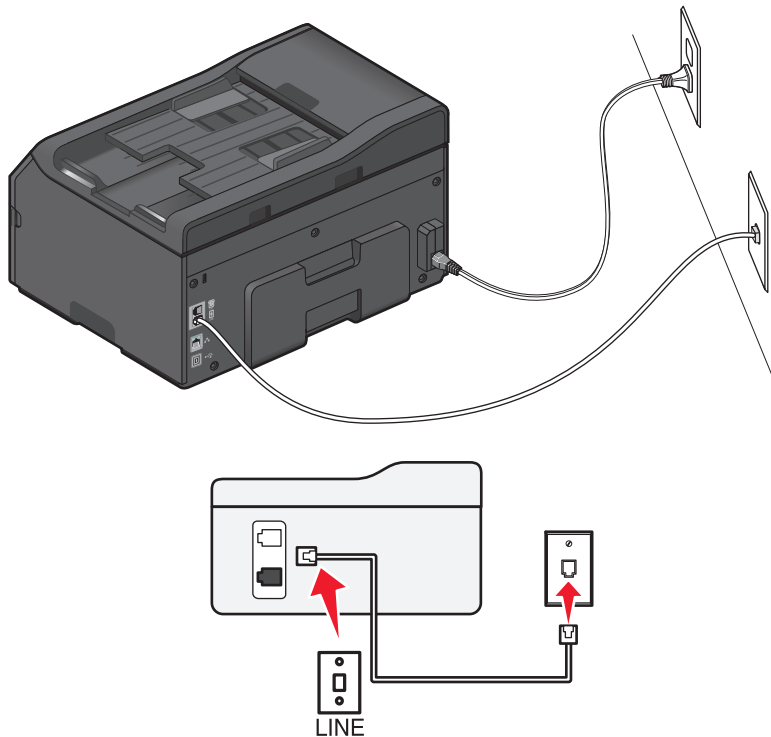

#### To connect:

Connect the cable from the wall jack to the  port of the printer.

#### Tips for this setup:



- You can set the printer to receive faxes automatically (Auto Answer On) or manually (Auto Answer Off).
- If you want to receive faxes automatically (Auto Answer On), then set the printer to pick up on any number of rings that you want.

### Setup 2: Printer is sharing the line with an answering machine

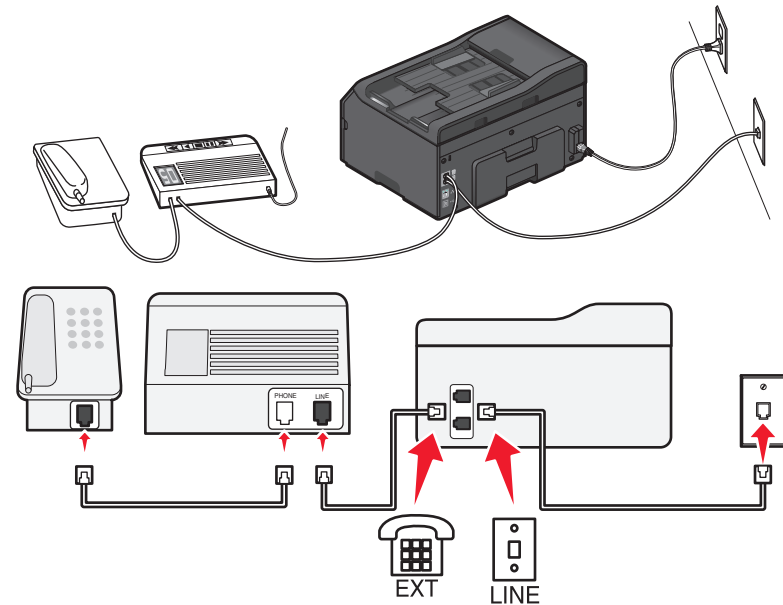
Connected to the same telephone wall jack





#### To connect:

- 1 Connect the cable from the wall jack to the  port of the printer.
- 2 Remove the protective plug from the  port of the printer, and then connect the answering machine to the port.

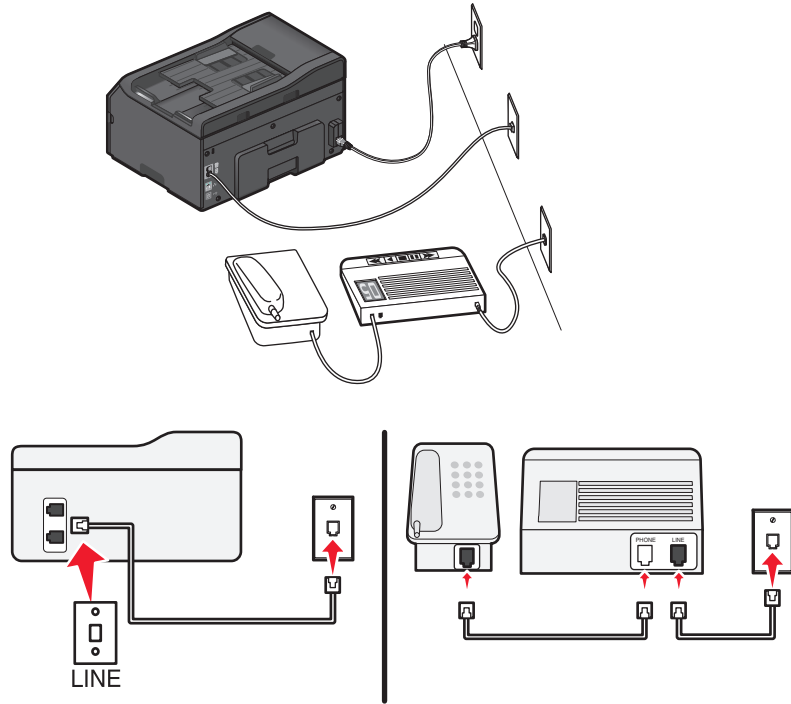

## Connected to different wall jacks



**To connect:**

Connect the cable from the wall jack to the  port of the printer.

**Tips for this setup:**

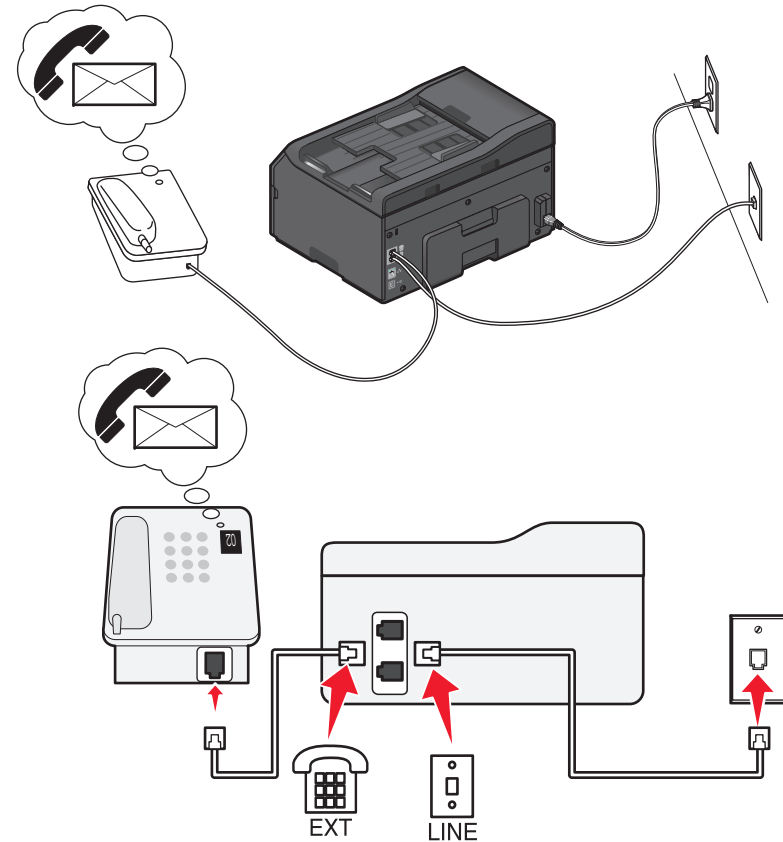
- If you have only one telephone number on your line, then you need to set the printer to receive faxes automatically (Auto Answer On).
- Set the printer to pick up calls two rings after the answering machine. For example, if the answering machine picks up calls after four rings, then set the printer to pick up after six rings. This way, the answering machine picks up calls first and your voice calls are received. If the call is a fax, then the printer detects the fax signal on the line and takes over the call.
- If you subscribe to a distinctive ring service provided by your telephone company, then make sure that you set the correct ring pattern for the printer. Otherwise, the printer will not receive faxes even if you have set it to receive faxes automatically.

**Setup 3: Printer is sharing the line with a telephone subscribed to voice mail service****To connect:**

- 1 Connect the cable from the wall jack to the  port of the printer.
- 2 Remove the protective plug from the  port of the printer, and then connect the telephone to the port.

**Tips for this setup:**

- This setup works best if you subscribe to a distinctive ring service. If you have distinctive ring service, then make sure that you set the correct ring pattern for the printer. Otherwise, the printer will not receive faxes even if you have set it to receive faxes automatically.
- If you have only one telephone number on your line, then you need to set the printer to receive faxes manually (Auto Answer Off).

When you answer the telephone and you hear fax tones, press \*9\* or the manual answer code on the telephone to receive the fax.

- You can also set the printer to receive faxes automatically (Auto Answer On), but you need to turn off the voice mail service when you are expecting a fax. This setting works best if you are using voice mail more often than fax.

## Scenario 2: Digital Subscriber Line (DSL)

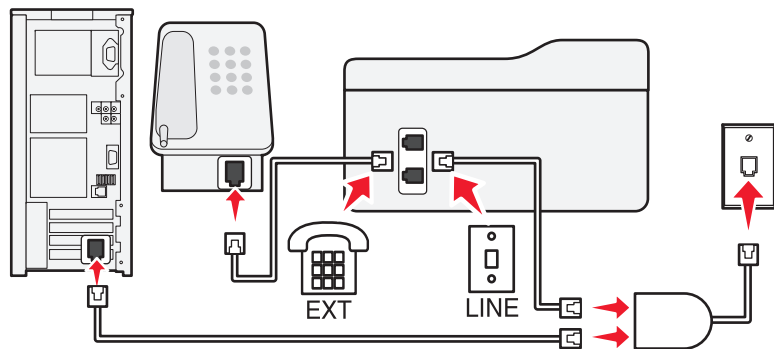
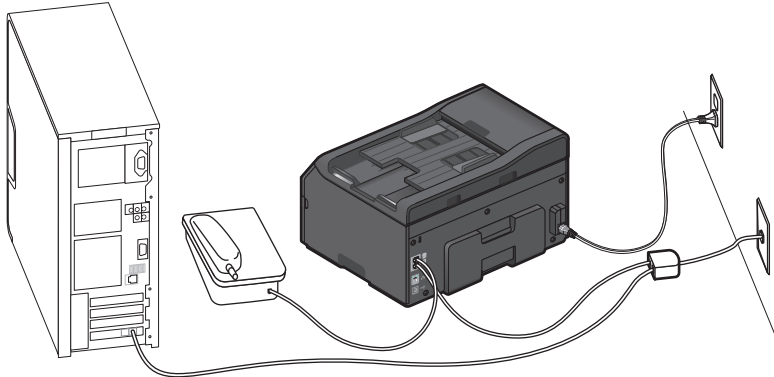



A Digital Subscriber Line splits your regular telephone line into two channels: voice and Internet. Telephone and fax signals travel through the voice channel, and Internet signals pass through the other channel. This way, you can use the same line for analog voice calls (including faxes) and digital Internet access.

To minimize interference between the two channels and ensure a quality connection, you need to install a DSL filter for the analog devices (fax machine, telephone, answering machine) in your network.

Interference causes noise and static on the telephone, failed and poor quality faxes for the printer, and slow Internet connection on your computer.



To install a filter for the printer:

- 1 Connect the line port of the DSL filter to the wall jack.
- 2 Connect a telephone cable from the  port on the back of the printer to the phone port on the DSL filter.
- 3 To continue using a computer for Internet access, connect the computer to the DSL HPN port on the DSL filter.
- 4 To connect a telephone to the printer, remove the protective plug from the  port of the printer and then connect the telephone to the port.

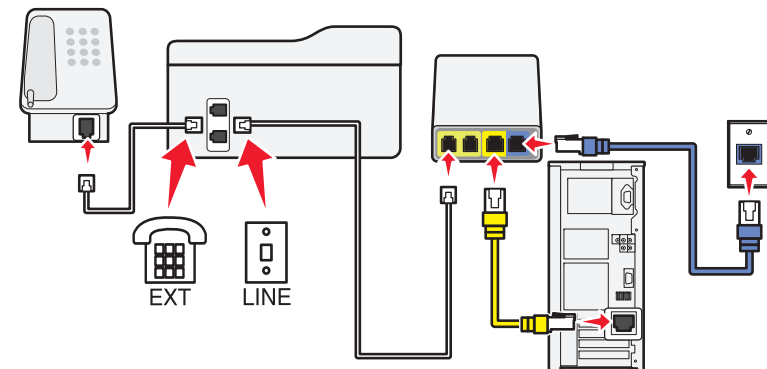
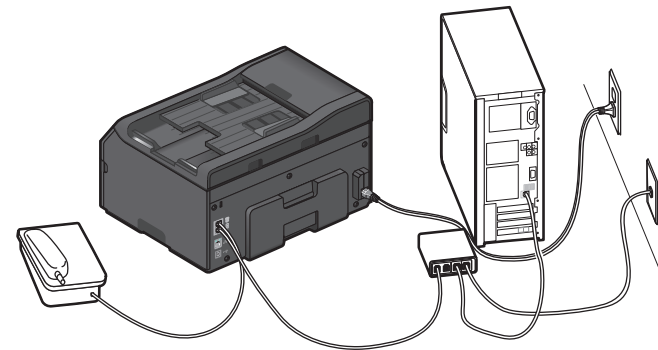
## Scenario 3: VoIP telephone service



**To connect:**

- 1 Connect one end of a telephone cable to the  port of the printer.
- 2 Connect the other end of the cable to the port labeled **Phone Line 1** or **Phone Port** on the VoIP adapter.  
The port labeled **Phone Line 2** or **Fax Port** is not always active. You may need to pay extra to your VoIP provider if you want to activate the second phone port.
- 3 Remove the protective plug from the  port of the printer, and then connect the telephone to the port.

**Tips for this setup:**



- To make sure that the phone port on the VoIP adapter is active, plug an analog telephone into the phone port, and then listen for a dial tone. If you hear a dial tone, then the port is active.
- If you need two phone ports for your devices but do not want to pay extra, then do not plug the printer into the second phone port. You can use a phone splitter. Plug the phone splitter into the **Phone Line 1** or **Phone Port**, and then plug the printer and telephone into the splitter.

Make sure you use a phone splitter, *not* a line splitter. To make sure that you are using the correct splitter, plug an analog telephone into the splitter and then listen for a dial tone.

**Scenario 4: Digital telephone service through a cable provider****Setup 1: Printer is connected directly to a cable modem**

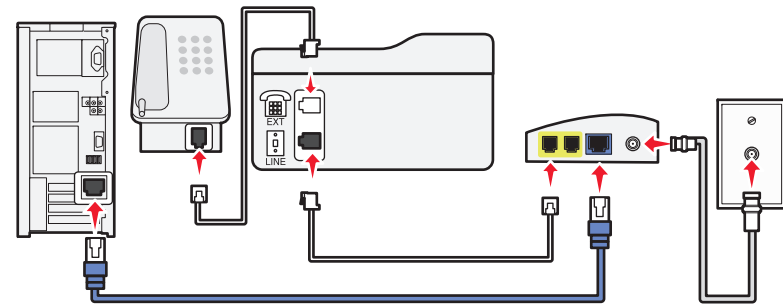
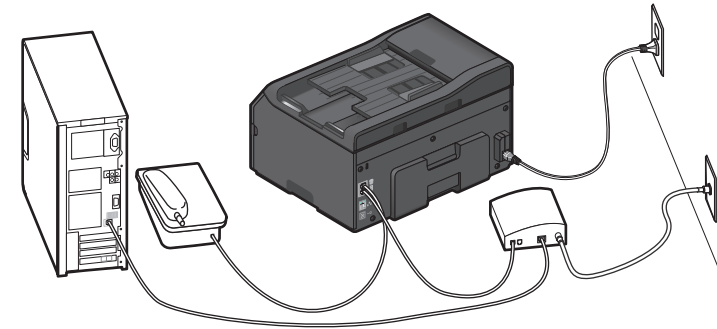
Follow this setup if you normally connect your telephone to a cable modem.

**To connect:**

- 1 Connect one end of a telephone cable to the  port of the printer.
- 2 Connect the other end of the cable to the port labeled **Phone Line 1** or **Phone Port** on the cable modem.  
The port labeled **Phone Line 2** or **Fax Port** is not always active. You may need to pay extra to your cable provider if you want to activate the second phone port.
- 3 Remove the protective plug from the  port of the printer, and then connect the telephone to the port.

**Tips for this setup:**

- To make sure that the phone port on the cable modem is active, plug an analog telephone into the phone port, and then listen for a dial tone. If you hear a dial tone, then the port is active.

- If you need two phone ports for your devices but do not want to pay extra, then do not plug the printer into the second phone port. You can use a phone splitter. Plug the phone splitter into the **Phone Line 1** or **Phone Port** , and then plug the printer and telephone into the splitter.

Make sure you use a phone splitter, *not* a line splitter. To make sure that you are using the correct splitter, plug an analog telephone into the splitter and then listen for a dial tone.

### Setup 2: Printer is connected to a wall jack; cable modem is installed elsewhere in the house

Follow this setup if your cable provider activated the wall jacks in your house so that you do not have to plug your devices into the cable modem. Your cable telephone service comes from the wall jacks.

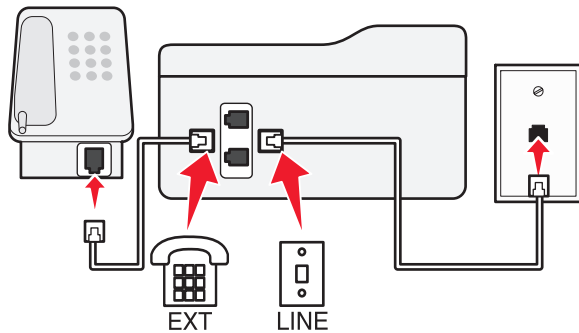
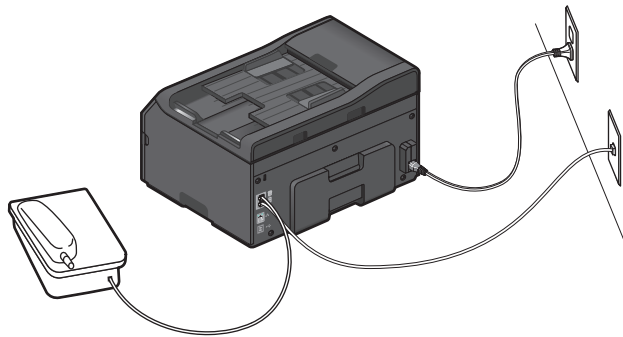

#### To connect:

- 1 Connect the cable from the wall jack to the  port of the printer.

- 2 Remove the protective plug from the  port of the printer, and then connect the telephone to the port.

### Scenario 5: Country- or region-specific setup

Different countries or regions have different types of telephone wall jacks. The standard wall jack adopted by most countries or regions is the Registered Jack-11 (RJ-11). You need to have an RJ-11 plug, or a telephone cable that has an RJ-11 connector, so you can connect a device to an RJ-11 wall jack.

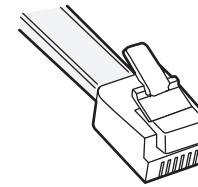

The fax ports on the back of the printer and the telephone cable that comes with the printer have RJ-11 connectors. If you have a different type of connector in your country or region, then you may need to use an RJ-11 adapter.

## Connecting the printer to a non-RJ-11 wall jack

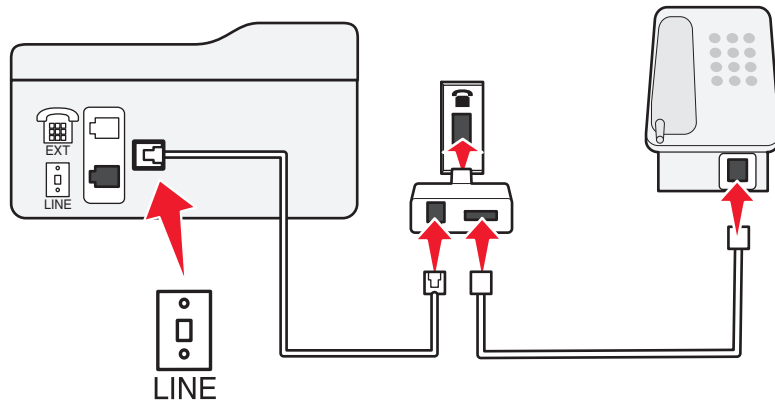
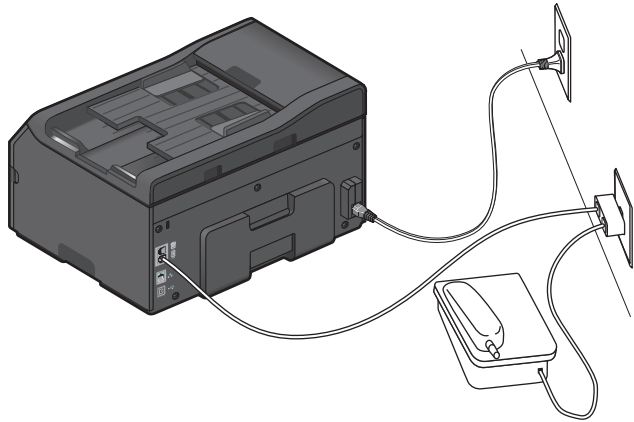

### To connect:

- 1 Connect one end of a telephone cable to the  port of the printer.
- 2 Connect the other end of the cable to the RJ-11 adapter, and then connect the adapter to the wall jack.
- 3 If you want to connect another device (telephone or answering machine) to the same wall jack, and if the device has a non-RJ 11 connector, then connect it directly to the wall jack.

### Notes:

- Do *not* remove the wrap plug from the  port of the printer.
- The printer may not come with an RJ-11 adapter in your country or region.

If the additional device (telephone or answering machine) has an RJ-11 connector, then you can remove the wrap plug and connect the device to the  port of the printer.

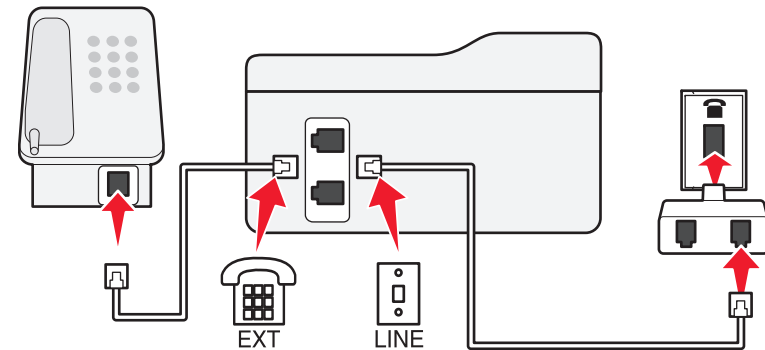
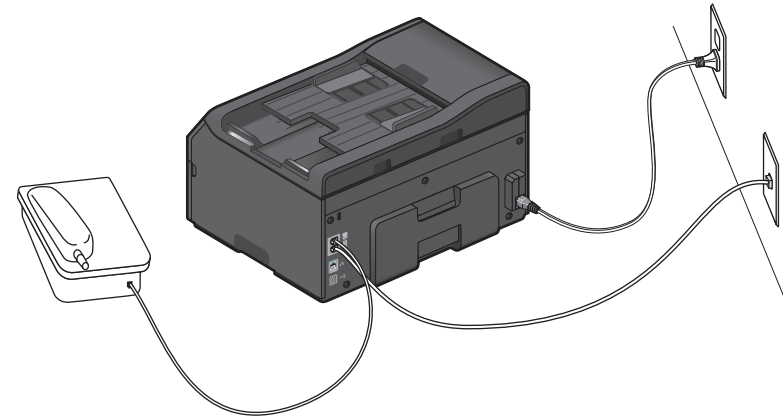

## Connecting the printer in countries or regions that use serial connection

In some countries or regions, you need to plug all devices into the wall jack. You cannot plug a telephone or answering machine into the  port of the printer. This is called *serial connection*.

Austria	Germany	Portugal
Belgium	Ireland	Spain
Denmark	Italy	Sweden

France

Netherlands

Switzerland

Finland

Norway

United Kingdom

**Warning—Potential Damage:** If your country or region is on the list, then do *not* remove the wrap plug from the  port of the printer. It is necessary for the proper functioning of the devices on the telephone line.

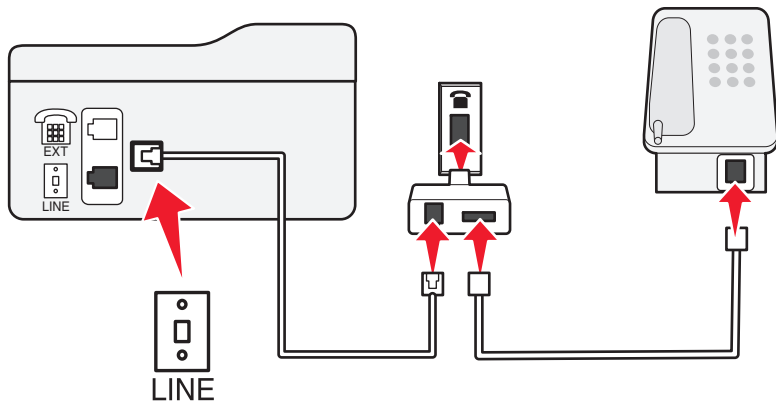
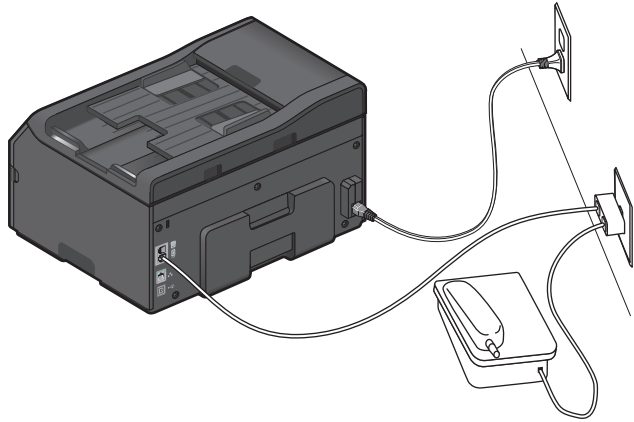

**To connect:**

Connect the cable from the wall jack to the  port of the printer.

### Connecting the printer to a wall jack in Germany

The German wall jack has two kinds of ports. The N ports are for fax machines, modems, and answering machines. The F port is for telephones.

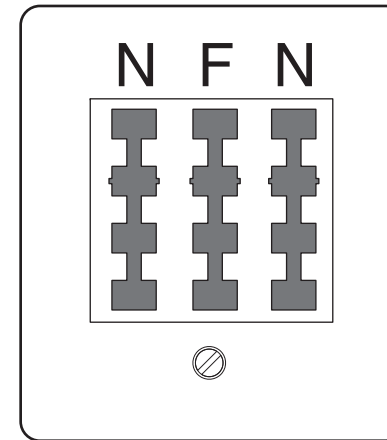

Connect the printer to any of the N ports.

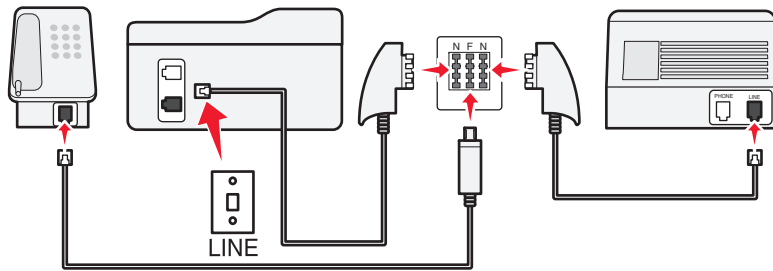
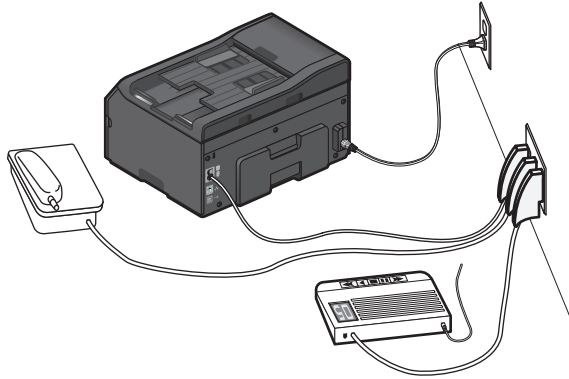

#### To connect:

- 1 Connect one end of a telephone cable to the  port of the printer.
- 2 Connect the other end of the cable to the RJ-11 adapter, and then connect the adapter to an N port.
- 3 If you want to connect a telephone and answering machine to the same wall jack, then connect the devices as shown.

## Step 2: Check the dial tone



A dial tone lets you know if the telephone line is working or if the printer is properly connected to the telephone line.

#### Make sure the telephone line and the wall jack are working

- 1 Plug an analog telephone into the wall jack.
- 2 Listen for a dial tone through the telephone handset.

If you hear a dial tone, then the telephone line and the wall jack are working.

#### Make sure the printer is properly connected to the telephone line

- 1 While the printer is connected to a telephone line through the  port on the back of the printer, plug an analog telephone into the  port of the printer.
- 2 Listen for a dial tone.

If you hear a dial tone, then the printer is properly connected to the telephone line.

If you do not hear a dial tone, then review Step 1 or see the “Fax troubleshooting checklist” on page 53.

## Step 3: Set your fax name and fax number

Your user information includes your name or your company name, your fax number (your fax number is your telephone number, unless you have a dedicated fax telephone line), and the time and date on your fax machine when a transmission is made. This information appears in the header and footer of the faxes that you send.

In some countries, you cannot send a fax without this information. Some fax machines also block faxes without sender information, so make sure that you enter this information in your printer.

- 1 From the printer control panel, navigate to:

 > Setup >  > Fax Setup >  > Dialing and Sending >  > Fax Name > 

- 2 Enter your name or your company name, and then press .

- To change a character, press the left arrow button.
- To add a space, press the number 0.

- 3 Press the arrow buttons to scroll to **Fax Number**, and then press .

- 4 Enter your fax number or your telephone number, and then press .

## Step 4: Set the printer to receive faxes automatically or manually

If the printer is connected to a dedicated fax line or sharing the line with an answering machine, then you can set the printer to receive faxes automatically. If the printer is sharing the line with a telephone subscribed to voice mail service, then set the printer to receive faxes manually.

- 1 From the printer control panel, navigate to:

 > Setup >  > Fax Setup >  > Ringing and Answering >  > Auto Answer > 

- 2 Press the arrow buttons to scroll to the setting you want, and then press .

## Step 5: Set the number of rings

If you set Auto Answer to On in Step 4, then do the following. If you set Auto Answer to Off, then proceed to Step 6.

### If you subscribe to Distinctive Ring

Setting the correct ring is important if you subscribe to the Distinctive Ring Pattern Detection (DPRD) feature offered by telephone companies. This feature allows you to have multiple telephone numbers on one telephone line. Each telephone number has a designated ring pattern (All Rings, Single Ring Only, Double Ring Only, Triple Ring Only, Single or Double Rings Only, Single or Triple Rings Only, Double or Triple Rings Only). The different ring patterns let you know which telephone number was dialed and which device you should use to answer the call.

Assign one of your telephone numbers to the printer as the fax number, and then set the printer to answer the ring pattern of that number. If the pattern is set incorrectly, then the printer rings, but it never receives the fax.

- 1 From the printer control panel, navigate to:

 > **Setup** >  > **Fax Setup** >  > **Ring Pattern** >  > **Ring Pattern** > 

- 2 Press the arrow buttons to scroll to the ring pattern you want, and then press .

### If you do not subscribe to Distinctive Ring

If the printer is sharing the line with other devices, then set the printer to pick up on the greater number of rings. If the printer is connected to a dedicated fax line, then you can choose any number of rings that you want.

- 1 From the printer control panel, navigate to:





 > **Setup** >  > **Fax Setup** >  > **Ring and Answering** >  > **Pick Up On** > 

- 2 Select the number of rings that you want, and then save the setting.

## Step 6: Create a contact list

### Using the printer control panel

- 1 From the printer control panel, navigate to:

Touch-screen models	Non-touch-screen models
 > <b>Address Book</b>	 > <b>Setup</b> >  > <b>Fax Setup</b> >  > <b>Address Book</b> > 

- 2 Use the menus to add a contact or a fax group. You can add up to 89 contacts and 10 fax groups.
  - To change a character, press the left arrow button.
  - To add a space, press the number 0.

**Note:** In some models, entries 1–89 are for individual contacts and entries 90–99 are for fax groups. Enter the number before entering the contact name and fax number of the contact.

### Using the fax software

If you are connecting the printer to a computer, then you can also create a contact list using the fax software.

#### For Windows users

- 1 Open the Contacts tab of the Printer Setup Utility.

##### In Windows 8

From the Search charm, type **printer home**, and then navigate to:  
Apps list > **Printer Home** > select your printer > **Fax** > **Edit contact list**

##### In Windows 7 or earlier

- a Click  or **Start**.
- b Click **All Programs** or **Programs**, and then select the printer program folder from the list.
- c Navigate to:  
**Printer Home** > select your printer > **Fax** > **Edit contact list**

The Contacts tab of the Printer Setup Utility opens.

- 2 Click **Select from phone book**.
- 3 From the Phone Book field, select a phone book.
- 4 Select the contact that you want to add, and then click **Add to or change list** to import the contact.

**Note:** To add contacts, you need to import contacts from the phone books on your computer that are supported by the fax software. In addition to the software Address Book, you may also have phone books of the mail clients installed on your computer, such as Microsoft Outlook.

- 5 Click **OK**.

#### For Macintosh users

- 1 From the Finder, navigate to:  
**Applications** > select your printer folder
- 2 Double-click **Printer Settings**.
- 3 Click the **Contacts** tab.
  - To add contacts, click the **Individuals** tab.
  - To add fax groups, click the **Groups** tab.

For more information on the fax software, click **Help** or .



## Faxing

 **CAUTION—SHOCK HAZARD:** Do not use the fax feature during a lightning storm. Do not set up this product or make any electrical or cabling connections, such as the fax feature, power cord, or telephone, during a lightning storm.

## Sending faxes

### Tips for sending faxes

- Make sure the printer is on and connected to a working telephone, DSL, or VoIP line. The line is working if you hear a dial tone.
- Make sure the paper exit tray is fully extended and the tray extension is flipped out.
- Depending on your printer model, use the ADF when scanning two-sided (duplex) pages.
- To easily retrieve a document after copying or scanning, lift the ADF input tray.
- When using the ADF, adjust the paper guide on the ADF to the width of the original document.
- When using the scanner glass, close the scanner cover, if possible, to avoid dark edges on the scanned image.
- Do *not* load postcards, photos, small items, transparencies, photo paper, or thin media (such as magazine clippings) into the ADF. Place these items on the scanner glass.
- When the document to be faxed is in place with the settings you want, press  to send the fax.

### Sending faxes using the printer control panel

1 From the printer control panel, navigate to:

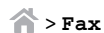



2 Enter a fax number, or press **Address Book** to select a number from the Speed Dial or Group Dial list.

3 If you want to send a fax to a single recipient, then press .

If you want to send a fax to a group of numbers (broadcast fax), then press the left or right arrow button to enter another number, and then press . Repeat this step to add more numbers.

4 Press the **Color/Black** button to select a color or black-and-white fax.

5 Press  to start the fax job.

**Warning—Potential Damage:** Do not touch the cables or the  and  ports while actively sending a fax.

#### Tip:

- You can send a broadcast fax to up to 30 recipients.

## Sending faxes using the computer

### For Windows users

- 1 With a document open, click **File > Print**.
- 2 Make sure to select the fax version of your printer, and then click **Properties, Preferences, Options, or Setup**.
- 3 Click the **Fax** tab, and then make sure **Enable Fax** is selected.
- 4 Enter the recipient fax number or numbers in the “Fax number(s)” field.  
You can enter fax numbers manually or by using the Phone Book feature.
- 5 If necessary, enter a prefix in the Dialing Prefix dialog.
- 6 Select the appropriate paper size and page orientation.
- 7 Select **Include Cover Page with Fax**, and enter the appropriate information if you want to include a cover page with the fax.
- 8 Click **OK**.

### For Macintosh users

- 1 With a document open, choose **File > Print**.
- 2 From the Printer pop-up menu, select the fax version of your printer.

**Note:** In order to see the fax options on the Print dialog, you must use the fax driver for your printer. If the fax version of the printer is not on the list, then choose **Add a printer**, and then choose the fax version of the printer.

- 3 Enter the name and number of the recipient.
- 4 Click **Fax**.

## Receiving faxes

### Tips for receiving faxes



When receiving faxes:

- Make sure that the printer is on and connected to a working telephone, DSL, or VoIP line. The line is working if you hear a dial tone.
- If you set the printer to receive faxes manually (Auto Answer Off), then make sure that the ringer volume is not set to Off.
- If you have set the printer to receive faxes automatically (Auto Answer On), then load paper in the printer.



## Receiving faxes automatically

- 1 Make sure that Auto Answer is on:



From the printer control panel, navigate to:

 > **Setup** >  > **Fax Setup** >  > **Ring and Answering** >  > **Auto Answer** >  > **On** > 

- 2 Set the number of rings before the printer picks up incoming faxes:

- a Press the arrow buttons to scroll to **Pick Up On**, and then press .
- b Press the arrow buttons to scroll to the number of rings that you want, and then press  to save the setting.

When the number of rings you set is detected, the printer automatically receives the incoming fax.

**Warning—Potential Damage:** Do not touch the cables or the  and  ports while actively receiving a fax.





### Tips:

- If the printer is sharing the line with other analog devices (telephone, answering machine), then set the printer to pick up calls two rings after the answering machine. For example, if the answering machine picks up calls after four rings, then set the printer to pick up after six rings. This way, the answering machine picks up calls first and your voice calls are received. If the call is a fax, then the printer detects the fax signal on the line and takes over the call. If the printer is on a dedicated fax line, then you may set the printer to pick up on any number of rings.
- If you have multiple numbers on a single line, or if you subscribe to a distinctive ring service provided by your telephone company, then make sure that you set the correct ring pattern for the printer. Otherwise, the printer will not receive faxes even if you have set it to receive faxes automatically.



## Receiving faxes manually

- 1 Turn off Auto Answer:

From the printer control panel, navigate to:



 > **Setup** >  > **Fax Setup** >  > **Ring and Answering** >  > **Auto Answer** >  > **Off** > 

- 2 When the telephone rings and you hear fax tones when you pick up the handset, press  on the printer or \*9\* on the telephone attached to the printer.

**Warning—Potential Damage:** Do not touch the cables or the  and  ports while actively receiving a fax.

### Tips:

- The default code for answering faxes manually is \*9\*, but for increased security, you can change it to a number that only you know. You can enter up to 7 characters for your code. The valid characters are the digits 0–9 and the characters # and \*.

- Make sure that the telephone is plugged into the  port on the back of the printer and that the printer is connected to the wall jack through the  port.

## Wireless networking

### Information you will need during wireless setup

To set up the printer for wireless printing, you need to know the following:

- The name of your wireless network, which is also known as the *SSID* (Service Set Identifier)
- If encryption was used to secure your network
- The security key (either a WEP key or WPA/WPA2 preshared key/passphrase)

To find the WPA/WPA2 preshared key/passphrase for the wireless network, see the documentation that came with the access point (wireless router), see the Web page associated with the access point, or consult your system support person.

If your access point is using WEP security, then the WEP key should be:

- Exactly 10 or 26 hexadecimal characters
- or*
- Exactly 5 or 13 ASCII characters

If your access point is using WPA or WPA2 security, then the WPA/WPA2 preshared key/passphrase should be:

- Exactly 64 hexadecimal characters
- or*
- From 8 to 63 ASCII characters

#### Notes:

- Hexadecimal characters are A–F, a–f, and 0–9.
- ASCII characters are letters, numbers, and symbols found on a keyboard. ASCII characters in a WPA/WPA2 preshared key/passphrase are case-sensitive.

If your wireless network is not using security, then you will not have a security key.

**Note:** If you do not know the SSID of the network that your computer is connected to, then launch the wireless utility of the computer network adapter and look for the network name. If you cannot find the SSID or the security information for your network, then see the documentation that came with the access point, or contact your system support person.

### Installing the printer on a wireless network

#### Using the Wireless Setup Utility (Windows only)

The Wireless Setup Utility lets you:

- Configure the printer to join an existing wireless network.
- Add a printer to an existing ad hoc network.

- Change the wireless settings after installation.
- Install the printer on additional network computers.

#### Notes:

- This program is applicable only in select printer models.
- Make sure the printer is turned on.
- Make sure the wireless network adapter installed in your printer is attached and working properly.
- Do *not* connect the installation or network cables until prompted to do so by the setup software.

#### Installing the Wireless Setup Utility (Windows only)

1 Obtain a copy of the software installer package.

- From the *Software and Documentation* CD that came with your printer
- From our Web site:  
Go to <http://support.lexmark.com>, and then navigate to:  
**SUPPORT & DOWNLOAD** > select your printer > select your operating system

2 Double-click the software installer package.

Wait for the installation dialog to appear.

If you are using a *Software and Documentation* CD and the installation dialog does not appear, then do the following:

##### In Windows 8

From the Search charm, type **run**, and then navigate to:  
Apps list > **Run** > type **D: \setup.exe** > **OK**

##### In Windows 7 or earlier

- Click , or click **Start** and then click **Run**.
- In the Start Search or Run dialog, type **D: \setup.exe**.
- Press **Enter**, or click **OK**.

**Note:** D is the letter of your CD or DVD drive.

3 Click **Install**, and then follow the instructions on the computer screen.

4 From the Available Software dialog, select **Wireless Setup Utility**.

#### Notes:

- Wireless Setup Utility is selected by default.
- If you want to install only the Wireless Setup Utility, then clear the other selected additional software.

5 Click **Continue**, and then follow the instructions on the computer screen.

## Launching the Wireless Setup Utility

1 Do the following:

### In Windows 8

From the Search charm, type **wireless setup utility**, and then navigate to:  
Apps list > **Wireless Setup Utility**

### In Windows 7 or earlier

- a Click  or **Start**.
- b Click **All Programs** or **Programs**.
- c Select the printer program folder from the list, and then select **Wireless Setup Utility**.

2 Follow the instructions on the computer screen.

## Using the Wireless Setup Assistant (Macintosh only)

The Wireless Setup Assistant lets you:

- Configure the printer to join an existing wireless network.
- Add a printer to an existing ad hoc network.
- Change the wireless settings after installation.
- Install the printer on additional network computers.

### Notes:

- This application is applicable only in select printer models.
- Make sure the printer is turned on.
- Make sure the wireless network adapter installed in your printer is attached and working properly.
- Do *not* connect the installation or network cables until prompted to do so by the setup software.
- Make sure that you are using the latest version of the Wireless Setup Assistant application. For more information, visit [www.lexmark.com](http://www.lexmark.com).

## Installing the Wireless Setup Assistant (Macintosh only)

- 1 Download the latest version of the Wireless Setup Assistant application from <http://support.lexmark.com>.
- 2 Double-click the downloaded software installer package.
- 3 Follow the instructions on the computer screen.

## Launching the Wireless Setup Assistant

- 1 From the Finder, navigate to:  
**Applications** > select your printer folder

2 Double-click **Wireless Setup Assistant**, and then follow the instructions on the computer screen.

**Note:** If you encounter problems while running the application, then click .

## What is Wi-Fi Protected Setup?

*Wi-Fi Protected Setup* (WPS) is a simple and secure configuration that allows you to establish a wireless home network and enable network security without requiring prior knowledge of Wi-Fi technology. It is no longer necessary to configure the network name (SSID) and WEP key or WPA passphrase for network devices.

**Note:** WPS supports only networks that communicate through access points (wireless routers).

The printer supports the following methods in connecting to a wireless network:

- *Personal Identification Number* (PIN)—A PIN on the printer is entered into the wireless settings of the access point.
- *Push Button Configuration* (PBC)—Buttons on both the printer and the access point are pushed within a given period of time.

Look for any of these identifier marks to check if your access point is WPS certified:



You can find these WPS logos on the side, back, or top of your access point.

For more information on accessing the wireless settings and determining the WPS capability of your access point, see the documentation that came with the access point or contact your system support person.







## Configuring Wi-Fi Protected Setup manually

**Note:** Make sure your access point (wireless router) is Wi-Fi Protected Setup (WPS) certified. For more information, see the *User's Guide*.

If your printer or device has not yet been configured for wireless connection and you want to configure it using WPS, then push the WPS button on the wireless router. Wait for the printer control panel to display a message to begin WPS configuration. There might be a short delay before the message appears. If nothing happens after 30 seconds, then do one of the following:

### USE THE PUSH BUTTON CONFIGURATION (PBC) METHOD







- 1 From the printer control panel, navigate to:

🏠 > Setup >  > Network Setup >  > Wireless 802.11b/g/n >  > Network Connection  
Setup >  > Wireless >  > Wi-Fi Protected Setup >  > WPS PBC Mode > 

2 Follow the instructions on the printer display.

## USE THE PERSONAL IDENTIFICATION NUMBER (PIN) METHOD

1 From the printer control panel, navigate to:

🏠 > Setup >  > Network Setup >  > Wireless 802.11b/g/n >  > Network Connection  
Setup >  > Wireless >  > Wi-Fi Protected Setup >  > WPS PIN Mode > 

2 Follow the instructions on the printer display.

## Using the Embedded Web Server

The Embedded Web Server lets you view and remotely customize printer settings even when you are not physically near the printer. You can also view reports on printer activities, monitor and order printer supplies online, contact customer support, and download updates for your printer.

The Embedded Web Server requires that the printer is connected to your network. For more information on connecting the printer to your network, see the printer *User's Guide*.

### Accessing the Embedded Web Server

**Note:** Make sure the printer is connected to your network. For more information, see the printer *User's Guide*.

**1** Obtain the printer IP address:

- From the printer home screen
- From the TCP/IP section in the Networks/Ports menu

**Note:** An IP address appears as four sets of numbers separated by periods, such as 123.123.123.123.

**2** Open a Web browser, and then type the printer IP address in the address field.  
The Embedded Web Server appears.

### Understanding the home page

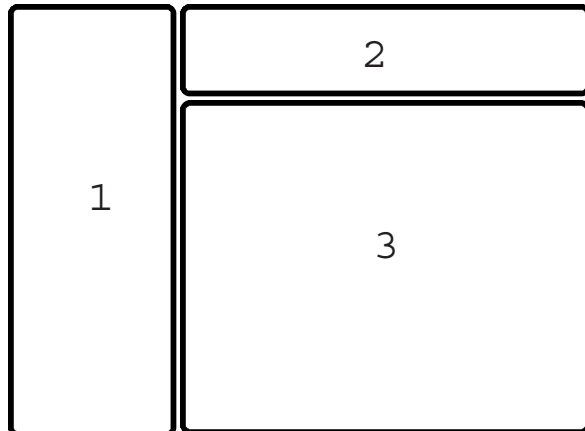

	Use the	To
1	Navigation pane	Access the Embedded Web Server menus.
2	Header bar	<ul style="list-style-type: none"> <li>• View a brief summary of your printer supplies.</li> <li>• View the information on printer model, IP address, contact information, and location.</li> <li>• Access the Search function.</li> </ul> <p><b>Note:</b> The search fields may not appear in the Embedded Web Server, depending on your printer model.</p>
3	Information pane	View specific information and access submenu items, depending on the menu selected from the navigation pane.

### Customizing printer settings

**1** From the navigation pane, select **Settings**.

**2** Do one of the following:

Click	To
General Settings	View and customize general printer settings.
Copy Settings	View and customize settings for making copies. <b>Note:</b> This feature may not appear in the Embedded Web Server, depending on your printer model.
Fax Settings	View and customize settings for sending and receiving faxes. <b>Note:</b> This feature may not appear in the Embedded Web Server, depending on your printer model.
E-mail/FTP Settings	View and customize settings for sending e-mails, or sending files to a <i>File Transfer Protocol (FTP)</i> address. <b>Note:</b> This feature may not appear in the Embedded Web Server, depending on your printer model.
Print Settings	View and customize print settings.
Paper Setup	View and customize paper setup options.
Network/Ports	View and customize network settings.
Security	View and customize security settings for the printer and Embedded Web Server. <b>Note:</b> This feature may not appear in the Embedded Web Server, depending on your printer model.
E-mail Alert Setup	Set up the e-mail server for the Embedded Web Server, and then customize e-mail alert settings.

Click	To
Scan-to-Network Folder Setup	Add or manage a folder destination when the Scan to Network application is used. <b>Notes:</b> <ul style="list-style-type: none"> <li>• This feature may not appear in the Embedded Web Server, depending on your printer model.</li> <li>• To use this feature, first make sure you are using the <i>Hyper Text Transfer Protocol Secure</i> (HTTPS) connection.</li> </ul>
Manage Shortcuts	Add or manage shortcut settings for a printer task. <b>Note:</b> This feature may not appear in the Embedded Web Server, depending on your printer model.
Manage Profiles	View the IP address of a profile, or delete it. <b>Note:</b> This feature may not appear in the Embedded Web Server, depending on your printer model.
Address Book Setup	Add or manage address book contacts when sending e-mails.
Intervention Management	View any messages from the printer requesting intervention from the user.
Import/Export	Import or export a configuration file.
Additional Solutions	Install, customize, or uninstall a solution.
Device Management	Allow the Embedded Web Server to collect data from the printer.

3 Click **Submit** to save, or click **Reset Form** to discard the new settings.

## Using shortcuts

### What are shortcuts?

A shortcut is a way to quickly accomplish printing, copying, scanning, e-mailing, or faxing tasks with the printer. You can configure and save a set of frequently used printer settings available for a given task and then assign a shortcut number and shortcut name to it.

The shortcut number and shortcut name serve as the identification for a particular task and its printer settings. When you want to perform a task with those settings, you do not need to go through the usual process of adjusting the settings and options. Simply enter the shortcut number or select the shortcut name and number on the printer control panel, and the task will launch automatically.

Configure the shortcut settings for a task in the Embedded Web Server:

Select	To
Copy	Copy a document or photo.
Eco-Copy	Copy a document or photo using two-sided or draft setting.
ID Card Copy	Copy both sides of an ID card onto a single page.
Scan to Fax	Scan a document or photo and send it through fax.
Scan to E-mail	Scan a document or photo and send it through e-mail. <b>Note:</b> Make sure the printer is connected to the network and the Internet through an Ethernet or wireless connection.
Scan to Computer	Scan a document or photo and send it to your computer. <b>Note:</b> Make sure the printer is connected to the computer locally (USB).
Scan to Network	Scan a document or photo and save it to a network folder. <b>Note:</b> Make sure the printer is connected to the Internet through an Ethernet or wireless connection.
Scan to Memory Device	Scan a document or photo and save it to a memory card or flash drive (depending on your printer model).
Print a File	Print a document from your computer. <b>Note:</b> Make sure the printer is connected to the computer through the same Ethernet or wireless network.

Example:

A lawyer who uses his printer to send e-mails to clients normally navigates through the printer control panel to select the feature and its available options. Instead of doing that, he can configure the printer settings (such as the message title and recipient) from the Embedded Web Server, and then assign a shortcut number and shortcut name to the task. Every time he enters the shortcut number or selects the shortcut name on the printer control panel, the printer automatically sends the documents according to the selected settings.

## Getting started

During installation, a link will be provided for you to create shortcuts. If you were not able to create your shortcuts during installation, then you may create the shortcuts through your printer software.

### Launching the shortcuts page using the printer software

Before you begin, make sure:

- Your printer and computer are each connected to the network through an Ethernet or wireless connection.
- Your printer is turned on.

#### For Windows users

- 1 Click  or **Start**.
- 2 Click **All Programs** or **Programs**, and then select the printer program folder from the list.
- 3 Navigate to:  
**Printer Home** > select your printer > **Settings** > **Configure Shortcuts**

#### For Macintosh users

- 1 From the Finder, navigate to:  
**Applications** > select your printer folder > **Shortcuts**
- 2 Select your printer from the list, and then click **Launch**.

### Creating a shortcut

- 1 Launch the shortcuts page, and then navigate to:  
**Add New Shortcut** > select a task
- 2 Assign a shortcut number and shortcut name, and then specify the settings.

#### Notes:

- A shortcut number is the number you assign to a particular task and its printer settings. You can assign shortcut numbers from 1 to 999.
- If you configured the shortcut to show the settings before running, then the settings will appear on the printer display. Adjust the settings if necessary.

- 3 Click **Add**.

### Modifying or deleting a shortcut

- 1 Launch the shortcuts page, and then select a shortcut.



2 Do either of the following:

- Make the necessary changes, and then click **Save Changes**.
- Click **Delete**.



## Using shortcuts on the printer

Make sure you have created a shortcut.

From the printer control panel, navigate to:

 > **Shortcuts** >  > select a shortcut > 

or

 >  > enter the shortcut number > 

**Note:** If you configured the shortcut to show the settings before running, then the settings will appear on the printer display. Adjust the settings if necessary.

## Troubleshooting

### Before you troubleshoot

Use this checklist to solve most printer problems:

- Make sure the power cord is plugged into the printer and into a properly grounded, working electrical outlet.
- Make sure the printer is turned on.
- Make sure the printer is securely connected to the computer, print server, or network access point.
- Check the printer for error messages, and resolve any errors.
- Check for paper jam messages, and clear any jams.
- Check the ink cartridges, and install new cartridges if necessary.
- Turn the printer off, wait about 10 seconds, and then turn the printer back on.

**Note:** Make sure the printer is not in Sleep mode. Press and hold  for three seconds to turn off the printer.

### If Troubleshooting does not solve your problem

Visit our Web site at <http://support.lexmark.com> to find the following:

- Knowledgebase articles with the latest information and troubleshooting for your printer
- Live online customer support
- Contact numbers for telephone customer support
- Firmware and software updates

### Setup troubleshooting

- "Installation screen did not appear during installation" on page 50
- "Incorrect language appears on the display" on page 50
- "Software did not install" on page 51
- "Recovering the security PIN of the printer" on page 51
- "Print job does not print or is missing pages" on page 51
- "Printer is printing blank pages" on page 52
- "Printer is busy or does not respond" on page 52
- "Cannot delete documents from the print queue" on page 52
- "Cannot print through USB" on page 52

### Installation screen did not appear during installation

If the "Before you troubleshoot" checklist does not solve the problem, then try the following:

#### For Windows users

- 1 Double-click the software installer package.

Wait for the installation dialog to appear.

If you are using a *Software and Documentation* CD and the installation dialog does not appear, then do the following:

#### In Windows 8

From the Search charm, type `run`, and then navigate to:

Apps list > **Run** > type `D:\setup.exe` > **OK**.

#### In Windows 7 or earlier

- a Click  or click **Start**, and then click **Run**.
- b In the Start Search or Run dialog, type `D:\setup.exe`.
- c Press **Enter**, or click **OK**.

**Note:** D is the letter of your CD or DVD drive.

- 2 Click **Install**, and then follow the instructions on the computer screen.

#### For Macintosh users

- 1 From the Finder desktop, click the CD icon.
- 2 Double-click the software installer package, and then follow the instructions on the computer screen.

### Incorrect language appears on the display

If the "Before you troubleshoot" checklist does not solve the problem, then try one or more of the following:

#### CHANGE THE LANGUAGE USING THE PRINTER MENUS

- 1 From the printer control panel, navigate to:

 > **Setup** > **OK** > **Device Setup** > **OK** > **Language** > **OK**

- 2 Press the up or down arrow button to scroll to the language you want, and then press **OK**.
- 3 To confirm the setting, press the left or right arrow button to scroll to **Yes**, and then press **OK**.

## Software did not install

If you encountered problems while installing, or if your printer does not appear in the list in the printers folder or as a printer option when sending a print job, then try uninstalling and reinstalling the software.

Before you reinstall the software, do the following:

### MAKE SURE THAT YOUR COMPUTER MEETS THE MINIMUM SYSTEM REQUIREMENTS

### TEMPORARILY DISABLE SECURITY PROGRAMS IN WINDOWS BEFORE INSTALLING THE SOFTWARE

### CHECK THE USB CONNECTION

- 1 Check the USB cable for any obvious damage. If the cable is damaged, then use a new one.
- 2 Firmly plug the square end of the USB cable into the back of the printer.
- 3 Firmly plug the rectangular end of the USB cable into the USB port of the computer.

The USB port is marked with .

**Note:** If you continue to have problems, then try another USB port on the computer. You may have connected to a defective port.

### RECONNECT THE PRINTER POWER SUPPLY

- 1 Turn off the printer.

**Note:** Make sure the printer is not in Sleep mode. Press and hold  for three seconds to turn off the printer.

- 2 Unplug the power cord from the wall outlet, and then pull out the power cord from the power supply.
- 3 After one minute, reconnect the power cord into the power supply, and then plug the power cord into the wall outlet.
- 4 Turn on the printer.

## Recovering the security PIN of the printer

Contact customer support.

## Print job does not print or is missing pages

If the "Before you troubleshoot" checklist does not solve the problem, then try one or more of the following:

### MAKE SURE THE INK CARTRIDGES ARE INSERTED CORRECTLY

- 1 Turn the printer on, and then open the ink cartridge access door.
- 2 Make sure the cartridges are inserted correctly.  
The cartridges should *click* firmly into their matching color slots.
- 3 Close the ink cartridge access door.

### SELECT YOUR PRINTER FROM THE PRINT DIALOG BEFORE SENDING THE PRINT JOB

**Note:** This solution applies to Macintosh users only.

- 1 With a document open, choose **File > Print**.
- 2 From the printer pop-up menu, choose your printer, and then click **Print**.

If your printer does not appear on the Printer list, then choose **Add Printer**. From the list of printers in the Default tab, select your printer, and then click **Add**.

If your printer does not appear on the list, then try either of the following:

- For a USB-connected printer, remove and then reconnect the USB cable.
- For a printer that is wirelessly connected, see the Wireless troubleshooting section.

### MAKE SURE THE PRINT JOB IS NOT PAUSED

### MAKE SURE YOUR PRINTER IS SET AS THE DEFAULT PRINTER

### RECONNECT THE PRINTER POWER SUPPLY

- 1 Turn off the printer.

**Note:** Make sure the printer is not in Sleep mode. Press and hold  for three seconds to turn off the printer.

- 2 Unplug the power cord from the wall outlet, and then pull out the power cord from the power supply.
- 3 After one minute, reconnect the power cord into the power supply, and then plug the power cord into the wall outlet.
- 4 Turn on the printer.

### REMOVE AND RECONNECT THE USB CABLE CONNECTED TO YOUR PRINTER

## CHECK THE USB CONNECTION

- 1 Check the USB cable for any obvious damage. If the cable is damaged, then use a new one.
- 2 Firmly plug the square end of the USB cable into the back of the printer.
- 3 Firmly plug the rectangular end of the USB cable into the USB port of the computer.

The USB port is marked with .

**Note:** If you continue to have problems, then try another USB port on the computer. You may have connected to a defective port.





## REMOVE AND REINSTALL THE PRINTER SOFTWARE

### Printer is printing blank pages

Blank pages may be caused by improperly installed ink cartridges.

#### REINSTALL THE INK CARTRIDGES AND DEEP CLEAN AND ALIGN THE PRINTHEAD

- 1 Reinstall the ink cartridges. For more information, see "Replacing ink cartridges" on page 17. The cartridges should *click* firmly into their matching color slots.
- 2 Load plain, unmarked paper.
- 3 From the printer control panel, navigate to:

 > Setup >  > Maintenance >  > Deep Clean Printhead > 

- 4 Press the up or down arrow button to scroll to a cleaning option, and then press . Wait until the printer is ready.

- 5 From the printer control panel, navigate to:

 > Setup >  > Maintenance >  > Align Printer > 

An alignment page prints.

**Note:** Do *not* remove the alignment page until printing is finished.

### Printer is busy or does not respond

If the "Before you troubleshoot" checklist does not solve the problem, then try one or more of the following:

#### MAKE SURE THE PRINTER IS NOT IN SLEEP MODE

If the power light is blinking on and off slowly, then the printer is in Sleep mode. Press  to wake up the printer.

If the printer will not come out of Sleep mode, then reset the power:

- 1 Unplug the power cord from the wall outlet, and then wait 10 seconds.
- 2 Insert the power cord into the wall outlet, and then turn on the printer.

If this problem persists, then check our Web site for updates for your printer software or firmware.

#### RECONNECT THE PRINTER POWER SUPPLY

- 1 Turn off the printer.

**Note:** Make sure the printer is not in Sleep mode. Press and hold  for three seconds to turn off the printer.

- 2 Unplug the power cord from the wall outlet, and then pull out the power cord from the power supply.
- 3 After one minute, reconnect the power cord into the power supply, and then plug the power cord into the wall outlet.
- 4 Turn on the printer.

### Cannot delete documents from the print queue

If you have jobs stuck in the print queue and cannot delete them to get other jobs to print, then the computer and printer may not be communicating.

#### RESTART THE COMPUTER AND TRY AGAIN

#### REMOVE AND RECONNECT THE USB CABLE CONNECTED TO YOUR PRINTER

### Cannot print through USB

If the "Before you troubleshoot" checklist does not solve the problem, then try one or more of the following:

#### CHECK THE USB CONNECTION

- 1 Check the USB cable for any damage. If the cable is damaged, then use a new one.
- 2 Firmly plug the square end of the USB cable into the back of the printer.
- 3 Firmly plug the rectangular end of the USB cable into the USB port of the computer.

The USB port is marked with .

**Note:** If you continue to have problems, then try another USB port on the computer. You may have connected to a defective port.

## MAKE SURE THE USB PORT IS ENABLED IN WINDOWS

- 1 Run the Device Manager.

### In Windows 8

From the Search charm, type **run**, and then navigate to:  
Apps list > **Run** > type **devmgmt.msc** > **OK**

### In Windows 7 or earlier

- a Click , or click **Start** and then click **Run**.
- b In the Start Search or Run dialog, type **devmgmt.msc**.
- c Press **Enter**, or click **OK**.

The Device Manager opens.

- 2 Click the plus sign (+) beside Universal Serial Bus controllers.  
If USB Host Controller and USB Root Hub are listed, then the USB port is enabled.

For more information, see the computer documentation.

## REMOVE AND REINSTALL THE PRINTER SOFTWARE

## Fax troubleshooting

- “Fax troubleshooting checklist” on page 53
- “Cannot send faxes” on page 53
- “Cannot receive faxes” on page 54
- “Cannot run the fax software” on page 55

## Fax troubleshooting checklist

If you encounter problems sending and receiving faxes, then check the connection first:

- 1 Check for a dial tone on the telephone line by plugging an analog telephone into the wall jack, DSL filter, VoIP device, or cable modem where you connected the printer. Make sure you plug the telephone into the same port.  
If you do not hear a dial tone, then contact your line provider.
- 2 While the printer is connected to the telephone line, check for a dial tone by plugging an analog telephone into the  port of the printer.  
If you do not hear a dial tone, then use the checklist below. Listen for a dial tone after checking each item.  
If you hear a dial tone but still have problems sending and receiving faxes, then see the other topics in this section.

## Connection checklist

- Make sure that the printer and other devices on the line (if applicable) are set up and configured correctly according to your setup scenario.
- Make sure that the cables are connected to the correct ports.
- Make sure that the cables are securely plugged in.

Check the cable connections for the following hardware, if applicable:

Power supply	Answering machine	Cable modem	Splitter
Telephone	VoIP adapter	DSL filter	RJ-11 adapter

- If the printer is connected to a Digital Subscriber Line, then make sure you are using a DSL filter for the printer.
- If the printer is connected to a VoIP adapter or cable modem, then make sure that the printer is plugged into the first phone port.
- If you are using a splitter, then make sure that you are using a phone splitter. Do *not* use a line splitter.

## Cannot send faxes

If the “Fax troubleshooting checklist” does not solve the problem, then try one or more of the following:





## MAKE SURE THAT YOU HAVE REGISTERED YOUR USER INFORMATION IN THE PRINTER

If you did not enter your user information during initial setup, then enter your fax name and fax number. In some countries, you cannot send a fax without entering your fax name or company name. Some fax machines also block unknown faxes or faxes without sender information.

## DECREASE THE TRANSMISSION SPEED OF THE FAX MODEM

The modem of the printer can transmit data at 33,600 bps. This is the maximum speed at which the printer can send and receive faxes. It is not necessary, however, to set the modem to its fastest transmission capability. The speed of the modem of the receiving fax machine must match or be greater than the speed at which you are sending your fax. Otherwise, your fax will not be received.

- 1 From the printer control panel, navigate to:





 > **Setup** >  > **Fax Setup** >  > **Dialing and Sending** >  > **Max Send Speed** > 

- 2 Select a sending speed, and then press .

## ENABLE ERROR CORRECTION

Errors and blurs may appear in the faxed document if there is too much noise on the line. This option enables the printer to transmit the bad blocks of data again and correct the errors. When a fax has too many errors, the fax may be rejected by the receiving fax machine.

- 1 From the printer control panel, navigate to:

 > **Setup** >  > **Fax Setup** >  > **Dialing and Sending** >  > **Error Correction** > 

- 2 Check to see if error correction is set to On.

If it is not set to On, then press the arrow buttons to select **On**, and then press **OK**.

### ENABLE AUTOMATIC FAX CONVERSION

If the receiving fax machine does not support color fax, then this option automatically converts the outgoing color fax to black and white. It also automatically reduces the resolution of the fax to a resolution that the receiving machine can support.

- 1 From the printer control panel, navigate to:

**Home** > **Setup** > **OK** > **Fax Setup** > **OK** > **Dialing and Sending** > **OK** > **Auto Fax Convert** > **OK**

- 2 Check to see if automatic fax conversion is set to On.

If it is not set to On, then press the arrow buttons to select **On**, and then press **OK**.

### MAKE SURE THAT THE DIAL PREFIX SETTING IS CORRECT

The dialing prefix is the number or series of numbers that you press before you can dial the actual fax number or telephone number. If the printer is in an office setting or in a private branch exchange, this can be a specific number that you need to press so you can make a call outside the office.

Make sure that the dial prefix entered in the printer is correct for your network.

- 1 From the printer control panel, navigate to:

**Home** > **Setup** > **OK** > **Fax Setup** > **OK** > **Dialing and Sending** > **OK** > **Dial Prefix** > **OK**

- 2 Press the arrow buttons to create or modify the prefix.

- 3 If the prefix is not correct, enter the correct prefix, and then press **OK**.

### Cannot receive faxes

If the “Fax troubleshooting checklist” does not solve the problem, then try one or more of the following:

#### MAKE SURE THAT YOU HAVE CONFIGURED THE CORRECT SETTINGS FOR YOUR SETUP

The fax settings depend on whether the printer is connected to its own fax line or shares the line with other devices.

If the printer is sharing the telephone line with an answering machine, then make sure that the following are set:

- Auto Answer is On.
- The printer picks up on a greater number of rings than the answering machine.
- The printer picks up on the correct distinctive ring (if you subscribe to a distinctive ring service).

If the printer is sharing the telephone line with a telephone subscribed to voice mail, then make sure that the following are set:

- Auto Answer is Off (if you have only one number on the telephone line).

- The printer picks up on the correct distinctive ring (if you subscribe to a distinctive ring service).

#### MAKE SURE THAT THE PRINTER IS CONNECTED TO AN ANALOG PORT

The printer is an analog device. If you are using a PBX system, then make sure that the printer is connected to an analog port on the PBX. You may need a digital line converter that converts digital signals into analog signals.

#### MAKE SURE THAT THE PRINTER MEMORY IS NOT FULL

The printer saves an incoming fax to the printer memory before it prints the fax. If the printer runs out of ink or runs out of paper while receiving the fax, then the printer saves the fax so you can print it later. However, if the printer memory is full, then the printer may not be able to receive more incoming faxes. An error message appears on the display when the printer memory is full. Resolve the error to free up space in the printer memory.

#### MAKE SURE THAT FAX FORWARDING IS DISABLED

- 1 From the printer control panel, navigate to:

**Home** > **Setup** > **OK** > **Fax Setup** > **OK** > **Ring and Answering** > **OK** > **Fax Forward** > **OK**

- 2 Press the arrow buttons to scroll to **Off**, and then press **OK**.

#### INCREASE THE RINGER VOLUME

If you set the printer to receive faxes manually (Auto Answer Off), then increase the ringer volume.

#### MAKE SURE THAT YOU HAVE THE CORRECT MANUAL ANSWER CODE

If you set the printer to receive faxes manually (Auto Answer Off), then you need to press the correct code when a fax comes in so that the printer can receive it.

- 1 From the printer control panel, navigate to:

**Home** > **Setup** > **OK** > **Fax Setup** > **OK** > **Ring and Answering** > **OK** > **Manual Pickup Code** > **OK**

- 2 Copy the manual answer code that appears on the display.

**Note:** To increase the security, you can change your manual pickup code to a number that only you know. You can enter up to 7 characters for your code. The valid characters are the digits 0–9 and the characters # and \*.

## Cannot run the fax software

The printer must be connected to a telephone, DSL, VoIP, or cable service before you can configure the fax settings in the fax software.

### MAKE SURE A FAX DRIVER IS INSTALLED

The fax option is available for use only with the PostScript driver or the Universal Fax Driver. For information on installing these drivers, see the *Software and Documentation CD*.

### MAKE SURE THE PRINTER IS CONNECTED TO A TELEPHONE LINE

You need to connect the printer to your telephone line (through a standard wall jack, a DSL filter, a VoIP adapter, or a cable modem) before you can open the fax software and configure the fax settings.

## Wireless troubleshooting

If you are having trouble setting up your printer on a network, then print a network setup page, and then see the comprehensive *User's Guide* available on the Software and Documentation CD.

Also, make sure to check the network indicator lights to verify the connection status of the printer. For more information on the location of the network indicator lights, see "Using the printer control panel" on page 14.

## Wireless troubleshooting checklist

Before beginning to troubleshoot the wireless printer, verify the following:

- The printer, the computer, and the access point (wireless router) are all plugged in and turned on.
- The wireless network is working properly.

Try accessing other computers on your wireless network.

If your network has Internet access, then try connecting to the Internet over a wireless connection.

- Your SSID is correct.

Print a network setup page to verify the SSID the printer is using.

If you are not sure if your SSID is correct, then run the wireless setup again.

- Your WEP key or WPA passphrase is correct (if your network is secure).

Log on to the access point and check the security settings.

A security key is like a password. All devices on the same wireless network using WEP, WPA, or WPA2 share the same security key.

If you are not sure if your security information is correct, then run the wireless setup again.

- The printer and the computer are within the range of the wireless network.

For most networks, the printer and the computer should be within 100 feet (30 meters) of the access point (wireless router).

- The Wi-Fi indicator is green and successfully connected.
- The printer driver is installed on the computer from which you are performing a task.

- The correct printer port is selected.
- The computer and printer are both connected to the same wireless network.
- The printer is located away from obstacles or electronic devices that could interfere with the wireless signal.

Make sure the printer and access point are not separated by poles, walls, or support columns containing metal or concrete.

Many devices can interfere with the wireless signal, including baby monitors, motors, cordless phones, security system cameras, other wireless networks, and some Bluetooth devices.

## Printing a network setup page

A *network setup page* lists the configuration settings of the printer, including the IP address and MAC address of the printer.

- 1 Load plain paper.
- 2 From the printer control panel, navigate to:

 > Setup >  > Network Setup >  > Print Network Setup Page > 

## Locating IP addresses

### For Windows users

- 1 Open the command window.

#### In Windows 8

From the Search charm, type **run**, and then navigate to:

Apps list > **Run** > type **cmd** > **OK**

#### In Windows 7 or earlier

- a Click , or click **Start** and then click **Run**.
- b In the Start Search or Run dialog, type **cmd**.
- c Press **Enter**, or click **OK**.

- 2 Type **ipconfig**, and then select **Go** or **Enter**.

The IP address appears as four sets of numbers separated by periods, such as 123.23.123.123.

### For Macintosh users

- 1 From the Apple menu, navigate to:

**About This Mac > More Info**

- 2 From the Contents pane, choose **Network**.

- 3 If you are connected over a wireless network, then choose **AirPort** from the Active Services list.

### Locating the printer IP address

- You can locate the printer IP address by viewing the printer network setup page. See the *User's Guide* on the software installation CD for more information on printing a network setup page.

### Cannot print over wireless network

If you encountered problems while installing, or if your printer does not appear in the printers folder or as a printer option when sending a print job, then try uninstalling and reinstalling the software.

Before you reinstall the software, check the troubleshooting checklist, and then try one or more of the following:

#### TURN THE ACCESS POINT (WIRELESS ROUTER) OFF AND THEN BACK ON

Wait one minute for the printer and computer to reestablish the connection. This can sometimes refresh network connections and resolve connectivity issues.

#### DISCONNECT FROM YOUR VPN SESSION

When you are connected to another network through a VPN connection, you will not be able to access the printer over your wireless network. End your VPN session, and then try printing again.

#### MAKE SURE DEMO MODE IS TURNED OFF

Select printer features are not available when Demo Mode is turned on.

From the printer control panel, navigate to:



#### CHECK YOUR WEP KEY OR WPA PASSPHRASE

If your access point is using WEP security, then the WEP key should be:

- Exactly 10 or 26 hexadecimal characters. Hexadecimal characters are A–F, a–f, and 0–9.  
or
- Exactly 5 or 13 ASCII characters. ASCII characters are letters, numbers, and symbols found on a keyboard. ASCII characters in a WEP key are case-sensitive.

If your access point is using WPA or WPA2 security, then the WPA/WPA2 preshared key/passphrase should be:

- Exactly 64 hexadecimal characters. Hexadecimal characters are A–F, a–f, and 0–9.  
or
- From 8 to 63 ASCII characters. ASCII characters are letters, numbers, and symbols found on a keyboard. ASCII characters in a WPA passphrase are case-sensitive.

**Note:** If you do not know this information, then see the documentation that came with the access point, or contact your system support person.

#### CHECK IF YOUR ACCESS POINT HAS AN ASSOCIATION/REGISTRATION BUTTON

Wireless broadband boxes in Europe, the Middle East, and Africa such as Livebox, AliceBox, N9UF Box, Freebox, or Club Internet may require you to press an association/registration button when adding the printer to your wireless network.

If you are using one of these boxes and need more information, then see the documentation that came with your box, or contact your *internet service provider* (ISP).

#### MOVE YOUR ACCESS POINT AWAY FROM OTHER ELECTRONIC DEVICES

There may be temporary interference from electronic devices such as microwave ovens or other appliances, cordless phones, baby monitors, and security system cameras. Make sure your access point is not positioned too closely to these devices.

#### MOVE THE COMPUTER, PRINTER, OR BOTH CLOSER TO THE ACCESS POINT

The range of your wireless network depends on many factors, including the abilities of your access point and network adapters. If you are having trouble printing, then try placing the computer and printer no more than 100 feet apart.

#### CHECK THE WIRELESS SIGNAL QUALITY

Print a network setup page and check the signal quality. If the signal quality is listed as good or excellent, then another factor is causing the problem.

#### CHECK YOUR ADVANCED SECURITY SETTINGS

- If you are using MAC (Media Access Control) address filtering to limit access to your wireless network, then you must add the printer MAC address to the list of addresses allowed to connect to the access point.
- If you set the access point to issue a limited number of IP addresses, then you must change this so that the printer can be added.

**Note:** If you do not know how to make these changes, then see the documentation that came with the access point, or contact the person who set up your wireless network.

#### MAKE SURE YOUR COMPUTER IS CONNECTED TO YOUR ACCESS POINT

- See if you have access to the Internet by opening your Web browser and accessing any site.
- If there are other computers or resources on your wireless network, then check to see if you can access them from your computer.

#### MAKE SURE THAT YOUR COMPUTER AND PRINTER ARE CONNECTED TO THE SAME WIRELESS NETWORK

If the printer is not on the same wireless network as the computer, then you will not be able to print wirelessly. The SSID of the printer must match the SSID of the computer, if the computer is already connected to the wireless network.



### For Windows users

- 1 Obtain the SSID of the network that the computer is connected to.
  - a Type the IP address of your access point into the address field of your Web browser.

If you do not know the IP address of the access point, then do the following:

- 1 Open the command window.

#### In Windows 8

From the Search charm, type **Run**, and then navigate to:  
Apps list > **Run** > type **cmd** > **OK**

#### In Windows 7 or earlier

- a Click , or click **Start** and then click **Run**.
- b In the Start Search or Run dialog, type **cmd**.
- c Press **Enter**, or click **OK**.

The command window opens.

- 2 Type **ipconfig**, and then press **Enter**. Check the Wireless Network Connection section:
  - The “Default Gateway” entry is typically the access point.
  - The IP address appears as four sets of numbers separated by periods, such as 192.168.2.134.

- b Type the user name and password of the access point when prompted.
- c Click **OK**.
- d In the Wireless settings section, look for the SSID.
- e Write down the SSID.

**Note:** Make sure you copy it exactly, including any capital letters.

- 2 Obtain the SSID of the network that the printer is connected to:
  - a From the printer, print a network setup page.
  - b In the Wireless section, look for **SSID**.
- 3 Compare the SSID of the computer and SSID of the printer.  
If the SSIDs are the same, then the computer and the printer are connected to the same wireless network.  
If the SSIDs are not the same, then run the utility again to set up the printer on the wireless network used by the computer.

### For Macintosh users with an AirPort base station

#### In Mac OS X version 10.5 or later

- 1 From the Apple menu, navigate to either of the following:
  - **System Preferences > Network > AirPort**
  - **System Preferences > Network > Wi-Fi**

The SSID of the network that the computer is connected to appears in the Network Name menu.

- 2 Write down the SSID.

#### In Mac OS X version 10.4 or earlier

- 1 From the Finder, navigate to:  
**Applications > Internet Connect > AirPort**  
The SSID of the network that the computer is connected to appears in the Network menu.
- 2 Write down the SSID.

### For Macintosh users with an access point

- 1 Type the IP address of the access point in the address field of your Web browser, and then continue to step 2.

If you do not know the IP address of the access point, then do the following:

- a From the Apple menu, navigate to either of the following:
  - **System Preferences > Network > AirPort**
  - **System Preferences > Network > Wi-Fi**

- b Click **Advanced** or **Configure**.

- c Click **TCP/IP**.  
The Router entry is typically the access point.

- 2 Type your user name and password when prompted, and then click **OK**.
- 3 In the Wireless settings section, look for the SSID.
- 4 Write down the SSID, security type, and the WEP key or WPA/WPA2 preshared key/passphrase (if shown).

#### Notes:

- Make sure you copy the network information down exactly, including any capital letters.
- Store the SSID and the WEP key or WPA/WPA2 preshared key/passphrase in a safe place for future reference.

### MAKE SURE YOUR OPERATING SYSTEM IS COMPATIBLE WITH WIRELESS PRINTING THROUGH AIRPORT

The printer supports wireless printing only through AirPort base stations for Mac OS X version 10.5 or later.

## “Communication not available” message appears when printing wirelessly

Try one or more of the following:

### MAKE SURE YOUR COMPUTER AND PRINTER HAVE VALID IP ADDRESSES FOR THE NETWORK

If you are using a laptop and have power saving settings enabled, then you may see the “Communication not available” message on your computer screen when you attempt to print wirelessly. This can occur if the laptop hard drive has powered down.

If you see this message, then wait a few seconds and then try to print again. The laptop and printer require a few seconds to power up again and reconnect to the wireless network.

If you see this message again after you have waited long enough for the printer and the laptop to connect to the network, then there may be a problem with your wireless network.

Make sure that the laptop and printer have both received IP addresses:

#### For Windows users

- 1 Open the command window.

##### In Windows 8

From the Search charm, type **run**, and then navigate to:  
Apps list > **Run** > type **cmd** > **OK**

##### In Windows 7 or earlier

- a Click , or click **Start** and then click **Run**.
- b In the Start Search or Run dialog, type **cmd**.
- c Press **Enter**, or click **OK**.

- 2 Type **ipconfig**, and then press **Enter**.

The IP address appears as four sets of numbers separated by periods, such as 192.168.0.100.















#### For Macintosh users

- 1 From the Apple menu, navigate to:  
**About This Mac > More Info**
- 2 From the Contents pane, choose **Network**.
- 3 If you are connected over a wireless network, then choose **AirPort** from the Active Services list.  
The Router entry is typically the access point.

#### Locating the printer IP address

- From the printer, print a network setup page.  
In the TCP/IP section, look for **Address**.
- View the printer settings.

From the printer control panel, navigate to either of the following:

-  > **Setup** >  > **Network Setup** >  > **Wireless 802.11 b/g/n** >  > **Network Connection Setup** >  > **TCP/IP** >  > **IP Address** > 
-  > **Setup** >  > **Network Setup** >  > **Ethernet 10/100** >  > **Network Connection Setup** >  > **TCP/IP** >  > **IP Address** > 

If the printer or the laptop does not have an IP address, or if either has an address of 169.254.x.y (where x and y are any two numbers between 0 and 255), then do the following:

- 1 Turn off the device that does not have a valid IP address (the laptop, the printer, or both).
- 2 Turn on the device, and then check the IP addresses again.

If the printer or the laptop still does not receive a valid IP address, then there is a problem with your wireless network. Try the following:

- Make sure your access point (wireless router) is turned on and is working.
- Remove any objects that could be blocking the signal.
- Temporarily turn off any unnecessary wireless devices on your network and pause any network-intensive activities, like large file transfers or network games. If the network is too busy, then it is possible that the printer is not receiving the IP address within the allowed time.
- Make sure your DHCP server, which may also be your wireless router, is working and is configured to assign IP addresses. If you are not sure how to do this, then refer to the manual that came with your wireless router.

If the printer and computer have valid IP addresses and the network is operating correctly, then continue troubleshooting.

### MAKE SURE THE WIRELESS PORT IS SELECTED

**Note:** This solution applies to Windows users only.

- 1 Open the printers folder.

#### In Windows 8

From the Search charm, type **run**, and then navigate to:  
Apps list > **Run** > type **control printers** > **OK**

#### In Windows 7 or earlier

- a Click , or click **Start** and then click **Run**.
- b In the Start Search or Run dialog, type **control printers**.
- c Press **Enter**, or click **OK**.

- 2 Right-click the printer, and then select **Printer properties** (for Windows 7 or later) or **Properties** (earlier versions).

- 3 Click the **Ports** tab, and then locate the selected port.

The selected port has a check mark beside it in the Port column.

- 4 If the Description column of the selected port indicates that it is a USB port, then scroll through the list and select the port with Printer Port in the Description column. Check the printer model in the Printer column to make sure you select the right printer port.
- 5 Click **OK**, and then try to print again.

### MAKE SURE BIDIRECTIONAL COMMUNICATION IS ENABLED

**Note:** This solution applies to Windows users only.

- 1 Open the printers folder.

#### In Windows 8

From the Search charm, type **run**, and then navigate to:

Apps list > **Run** > type **control printers** > **OK**

#### In Windows 7 or earlier

- a Click , or click **Start** and then click **Run**.
  - b In the Start Search or Run dialog, type **control printers**.
  - c Press **Enter**, or click **OK**.
- 2 Right-click the printer, and then select **Properties** (for Windows Vista or earlier) or **Printer properties** (for Windows 7 or later).
  - 3 Click the **Ports** tab.
  - 4 Click the box next to **Enable bidirectional support** if it is not already checked.
  - 5 Click **Apply** > **OK**, and then try to print again.

## Ethernet network troubleshooting

### Printer does not appear in the list of printers found on the network

#### CHECK THE ETHERNET CABLE

- Check the Ethernet cable and the Ethernet connectors at both ends for any obvious damage.
- Firmly plug one end of the Ethernet cable into the printer. Firmly plug the other end of the Ethernet cable into the network hub or wall connection.
- Try using a different cable. Damage to the cable may not be obvious.

#### MAKE SURE THE PRINTER POWER IS ON

Make sure the printer is connected to a power source and is turned on.

#### MAKE SURE THAT THE NETWORK IS OPERATING PROPERLY

- Try to access other computers on the network.

- Make sure all switches, hubs, and other connecting devices are turned on.

#### MAKE SURE THE PRINTER HAS VALID NETWORK SETTINGS

Print a network setup page from the printer and check the following. See the “Networking” section of the *User's Guide* for instructions on how to print a network setup page.

- Verify that the IP address is correct for your network.
- Verify that the gateway is correct.
- Verify that the network mask is the same as the network mask used for other computers and printers on your network.

### Cannot print to the network printer

#### CHECK THE ETHERNET CABLE

- Check the Ethernet cable and the Ethernet connectors at both ends for any obvious damage.
- Firmly plug one end of the Ethernet cable into the printer. Firmly plug the other end of the Ethernet cable into the network hub or wall connection.
- Try using a different cable. Damage to the cable may not be obvious.

#### MAKE SURE THE PRINTER POWER IS ON

Make sure the printer is connected to a power source and is turned on.

#### MAKE SURE THAT THE NETWORK IS OPERATING PROPERLY

- Try to access other computers on the network.
- Make sure all switches, hubs, and other connecting devices are turned on.

#### UNINSTALL AND REINSTALL THE SOFTWARE

See the “Reinstalling the printer software” section of the *User's Guide*.

## Notices

### Edition notice

October 2012

**The following paragraph does not apply to any country where such provisions are inconsistent with local law:** LEXMARK INTERNATIONAL, INC., PROVIDES THIS PUBLICATION "AS IS" WITHOUT WARRANTY OF ANY KIND, EITHER EXPRESS OR IMPLIED, INCLUDING, BUT NOT LIMITED TO, THE IMPLIED WARRANTIES OF MERCHANTABILITY OR FITNESS FOR A PARTICULAR PURPOSE. Some states do not allow disclaimer of express or implied warranties in certain transactions; therefore, this statement may not apply to you.

This publication could include technical inaccuracies or typographical errors. Changes are periodically made to the information herein; these changes will be incorporated in later editions. Improvements or changes in the products or the programs described may be made at any time.

References in this publication to products, programs, or services do not imply that the manufacturer intends to make these available in all countries in which it operates. Any reference to a product, program, or service is not intended to state or imply that only that product, program, or service may be used. Any functionally equivalent product, program, or service that does not infringe any existing intellectual property right may be used instead. Evaluation and verification of operation in conjunction with other products, programs, or services, except those expressly designated by the manufacturer, are the user's responsibility.

For Lexmark technical support, visit <http://support.lexmark.com>.

For information on supplies and downloads, visit [www.lexmark.com](http://www.lexmark.com).

© 2012 Lexmark International, Inc.

All rights reserved.

### GOVERNMENT END USERS

The Software Program and any related documentation are "Commercial Items," as that term is defined in 48 C.F.R. 2.101, "Computer Software" and "Commercial Computer Software Documentation," as such terms are used in 48 C.F.R. 12.212 or 48 C.F.R. 227.7202, as applicable. Consistent with 48 C.F.R. 12.212 or 48 C.F.R. 227.7202-1 through 227.7207-4, as applicable, the Commercial Computer Software and Commercial Software Documentation are licensed to the U.S. Government end users (a) only as Commercial Items and (b) with only those rights as are granted to all other end users pursuant to the terms and conditions herein.

### Trademarks

Lexmark and Lexmark with diamond design are trademarks of Lexmark International, Inc., registered in the United States and/or other countries.

All other trademarks are the property of their respective owners.

### Federal Communications Commission (FCC) compliance information statement

This product complies with the limits for a Class B digital device, pursuant to Part 15 of the FCC Rules. Operation is subject to the following two conditions:

- 1 this device may not cause harmful interference, and
- 2 this device must accept any interference received, including interference that may cause undesired operation.

Any questions on this statement should be directed to:

Director of Lexmark Technology & Services  
Lexmark International, Inc.  
740 West New Circle Road  
Lexington, KY 40550  
(859) 232-3000

For additional compliance information, see the online documentation.

### Federal Communications Commission (FCC) compliance information statement

This product complies with Part 68 of the FCC Rules. See the product online documentation for additional compliance information.

# Index

## A

- adding
  - network folder shortcut 28
- Additional Solutions
  - customize printer settings using 46
- Address Book 40
- Address Book Setup
  - customize printer settings using 46
- ADF input tray
  - location 12
- aligning the printhead 18
- answering machine
  - setting up 32
- Automatic Document Feeder (ADF)
  - location 12

## B

- bidirectional communication
  - enabling 58
- bin extender
  - location 13
- broadcast fax, sending
  - immediately 41
- buttons, printer control panel
  - Address Book 15
  - arrow buttons 14
  - Back 14
  - Black 15
  - Cancel 15
  - Color 15
  - Dial Tone 14
  - Home 14
  - keypad 14
  - Pause 14
  - Power 14
  - Redial 14
  - Select 14
  - Start 15

## C

- Caller ID
  - setting 39
- canceling
  - copy job 27
  - e-mail 31

- print job 24
- scan job 30
- cannot delete documents from print queue 52
- cannot print over wireless network 56
- cannot print through USB 52
- cannot print to network printer 59
- cannot receive faxes 54
- cannot run fax software 55
- cannot send faxes 53
- card reader light
  - location 12
- cartridges, ink
  - ordering 17
- checking an unresponsive printer 50
- checking the dial tone 39
- checklist
  - before you troubleshoot 50
  - fax troubleshooting 53
- cleaning printhead nozzles 18
- Communication not available
  - message 58
- configuring Wi-Fi Protected Setup
  - PBC, Push Button Configuration method 44
  - PIN, Personal Identification Number method 44
- conserving energy, ink, and paper 5
- contact list
  - creating 40
- copies
  - making 26
- copy job
  - canceling 27
- Copy Settings
  - customize printer settings using 46
- copying 26
  - on both sides of the paper 26
  - tips 26
- customer support 50
- customer support label
  - location 13

## D

- Device Management
  - customize printer settings using 46
- dial tone
  - checking 39
- Digital Subscriber Line (DSL)
  - fax setup 34
- digital telephone service
  - fax setup 35

- distinctive ring
  - setting 40
- documents
  - adding a network folder shortcut 28
  - faxing using the computer 41
  - faxing using the control panel 41
  - printing 23
  - scanning using the printer control panel 28
  - scanning using the touch screen 28
- DSL filter 34
- duplex
  - copying, automatic 26
  - printing, automatic 23
- duplex unit
  - location 13

## E

- Embedded Web Server
  - accessing 46
- emission notices 60
- energy
  - conserving 5
- Ethernet port
  - location 13
- exit bin
  - location 13
- EXT port
  - location 13
- e-mail
  - canceling 31
- E-mail Alert Setup
  - customize printer settings using 46
- e-mail function
  - setting up 31
- E-mail/FTP Settings
  - customize printer settings using 46
- e-mailing
  - scanned documents 29
  - setting up e-mail function 31
  - tips 31

## F

- Fax Settings
  - customize printer settings using 46
- fax setup
  - country- or region-specific 36
  - digital telephone service 35
  - DSL connection 34
  - standard telephone line connection 32

- VoIP 34
- fax troubleshooting
  - cannot receive faxes 54
  - cannot run fax software 55
  - cannot send faxes 53
- fax troubleshooting checklist 53
- faxing
  - Auto Answer setting 39
  - receiving automatically 42
  - receiving manually 42
  - sending a broadcast fax immediately 41
  - sending using the control panel 41
  - setting sender information 39
  - tips, receiving 41
  - tips, sending 41
  - using the computer 41
  - using the control panel 41
- faxing tips
  - receiving faxes automatically 42
- FCC notices 60
- features, printer 6
- file types
  - supported 15
- finding
  - information 5
  - publications 5
  - Web site 5
- finding IP address of computer (Mac) 55
- flash drive
  - inserting 15
  - printing documents from 24
  - scanning to 29

## G

- General Settings
  - customize printer settings using 46
- Group List 40

## H

- header bar 46
- home page
  - areas 46
  - understanding 46

## I

- Import/Export
  - customize printer settings using 46
- incorrect language appears on display 50

information  
 finding 5

information pane 46

information you will need during wireless setup 43

ink  
 conserving 5

ink cartridge access door  
 location 12

ink cartridges  
 ordering 17  
 replacing 17

inserting a memory card or flash drive 15

installation screen did not appear automatically 50

installing printer software (Windows) 19

Intervention Management  
 customize printer settings using 46

**L**

language  
 changing 50

LexPrint 25

line filter 34

LINE port  
 location 13

**M**

Macintosh printer software  
 using 20

Manage Profiles  
 customize printer settings using 46

Manage Shortcuts  
 customize printer settings using 46

memory card  
 inserting 15  
 printing documents from 24  
 scanning to 29  
 supported types 15

memory card slot  
 location 12

minimum system requirements 19

models, printer 5

moving the printer 18

**N**

navigation pane 46

network setup page  
 printing 55

network troubleshooting  
 cannot print to network printer 59  
 printer to be configured does not appear in list of printers found on network 59

Network/Ports  
 customize printer settings using 46

networking  
 finding IP address of computer 55  
 finding IP address of computer (Mac) 55  
 finding IP address of printer 55  
 IP addresses 55

notices 2, 60

**P**

page does not print 51

paper  
 conserving 5

Paper Setup  
 customize printer settings using 46

paper tray  
 location 13

paper, recommended brands  
 types and sizes 22

parts  
 diagram 12

PDF  
 creating from scan 29

Personal Identification Number method  
 using 44

phone book 40

phone plug 36

phone splitter 34

photos  
 printing from a memory card or flash drive 24

PictBridge and USB port  
 location 12

power supply port  
 location 13

Print dialog  
 launching 20

print job  
 canceling 24

Print Settings  
 customize printer settings using 46

print troubleshooting  
 cannot delete documents from print queue 52

printer  
 features 6  
 models 5  
 moving 18  
 setting up 6

printer control panel  
 buttons 14  
 display 14

Ethernet indicator 14

layout 14

location 13  
 using 14

Wi-Fi indicator 15

printer does not respond 52

printer features 6

printer models 5

printer printing blank pages 52

printer problems, basic solutions 50

printer settings, customizing  
 Additional Solutions 46  
 Address Book Setup 46  
 Copy Settings 46  
 Device Management 46  
 E-mail Alert Setup 46  
 E-mail/FTP Settings 46  
 Fax Settings 46  
 General Settings 46  
 Import/Export 46  
 Intervention Management 46  
 Manage Profiles 46  
 Manage Shortcuts 46  
 Network/Ports 46  
 Paper Setup 46  
 Print Settings 46  
 Scan-to-Network Folder Setup 46  
 Security 46

printer software, installing (Windows) 19

printer to be configured does not appear in list of printers found on network 59

printers  
 supported 25

printhead  
 aligning 18

printhead nozzles  
 cleaning 18

printing  
 advanced color 23  
 documents 23  
 documents from memory card or flash drive 24

network setup page 55  
 on both sides of the paper 23  
 photos from a memory card or flash drive 24  
 two-sided 23

printing using advanced color options 23

publications  
 finding 5

Push Button Configuration method  
 using 44

**R**

receiving faxes  
 Auto Answer setting 39, 42  
 automatically 42  
 manually 42  
 tips 42

recommended paper brands  
 types and sizes 22

recovering the security PIN 51

recycling 5

replacing ink cartridges 17

RJ-11 adapter 36

**S**

safety information 2, 32

scan job  
 canceling 30

scanner glass  
 location 13

scanning  
 creating a PDF from scan 29  
 documents for e-mailing 29  
 tips 28  
 to a flash drive 29  
 to a local computer 28  
 to a memory card 29  
 to a network 28  
 to a network folder 28  
 using the printer control panel 28  
 using the touch screen 28

Scan-to-Network Folder Setup  
 customize printer settings using 46

Security  
 customize printer settings using 46

security PIN  
 recovering 51  
 selecting the wireless port 58

sender information  
 registering 39

- sending faxes, tips 41
- setting
  - number of rings 40
- setting up fax
  - country- or region-specific 36
  - digital telephone service 35
  - DSL connection 34
  - standard telephone line connection 32
  - VoIP connection 34
- setting up printer 6
- setup troubleshooting
  - cannot print through USB 52
  - incorrect language appears on display 50
  - installation screen did not appear automatically 50
  - page does not print 51
  - printer does not respond 52
  - printer printing blank pages 52
  - recovering security PIN 51
  - software did not install 51
- shortcut
  - creating 48
  - deleting 48
  - modifying 48
- shortcuts 48
  - using shortcuts on printer 49
- shortcuts page
  - launching 48
- software did not install 51
- Speed Dial list 40
- supported memory cards and file types 15
- supported operating systems 19
- supported printers 25

**T**

- telecommunication notices 60
- tips for
  - copying 26
  - e-mailing 31
  - receiving faxes 41
  - scanning 28
  - sending faxes 41
- Transmit Terminal Identification (TTI)
  - setting 39
- troubleshooting
  - checking an unresponsive printer 50
  - contacting customer support 50
  - fax checklist 53
  - solving basic printer problems 50

- wireless network 55
- troubleshooting, fax
  - cannot receive faxes 54
  - cannot run fax software 55
  - cannot send faxes 53
- troubleshooting, network
  - cannot print to network printer 59
  - printer to be configured does not appear in list of printers found on network 59
- troubleshooting, print
  - cannot delete documents from print queue 52
- troubleshooting, setup
  - cannot print through USB 52
  - incorrect language appears on display 50
  - installation screen did not appear automatically 50
  - page does not print 51
  - printer does not respond 52
  - printer printing blank pages 52
  - recovering security PIN 51
  - software did not install 51
- troubleshooting, wireless
  - cannot print over wireless network 56
- two-sided
  - copying, automatic 26
- two-sided printing
  - supported paper sizes and paper types 23

**U**

- USB port
  - location 13
- using
  - Wireless Setup Utility 44

**V**

- voice mail
  - setting up 32
- Voice over Internet Protocol (VoIP)
  - fax setup 34
- VoIP adapter 34

**W**

- Web Links
  - accessing 20
- Web site
  - finding 5
- Windows software
  - Abbyy Sprint OCR 20

- Phone Book 20
- Printer Home 20
- Printer Setup Utility 20
- Printing Preferences 20
- Product Update 20
- Status Messenger 20
- Status Monitor Center 20
- Tools for Office 20
- Wireless Setup Utility 20
- wireless network
  - information you will need for setting up wireless printing 43
  - troubleshooting 55
- wireless setup
  - information needed for 43
- Wireless Setup Assistant
  - launching 44
- Wireless Setup Assistant (Macintosh only)
  - installing 44
- Wireless Setup Assistant (Macintosh)
  - using 44
- Wireless Setup Utility
  - launching 44
- Wireless Setup Utility (Windows only)
  - installing 43
- Wireless Setup Utility (Windows)
  - using 43
- wireless troubleshooting
  - cannot print over wireless network 56
- Wi-Fi Protected Setup
  - configuring manually 44
  - using 44
- Wi-Fi Protected Setup logo
  - identifying 44